



CEASE FIRE

The Fire and Safety Experts



Over 500
Quality Products



State-of-the-Art
Manufacturing



International
Certifications



PRODUCT
CATALOGUE

FIRE EXTINGUISHERS | IN-PANEL SYSTEMS | KITCHEN SYSTEMS | SUPPRESSION SYSTEMS |
ALARM SOLUTIONS | ACCESSORIES | AMC | REFILLING

ABOUT US

Ceasefire is the most trusted fire safety brand in India and a fast emerging global conglomerate. With its globally certified, holistically integrated range of fire fighting solutions, the company is amongst the rarest in the world to have such a diverse product portfolio as part of one eco-system. The company is a leading manufacturer of a 360 degree unified product range that includes a complete line of Fire Extinguishers

with the widest Variety of extinguishing agents, **Special Application Extinguishers**, Highly advanced **In-Panel Suppression Systems**, **Total Flooding Systems**, Greenest technologies including **Inert Gas Based Suppression Systems**, Revolutionary **Watermist Based Suppression Systems**, Extensive range of Watermist and Wet chemical Based **Kitchen Fire Suppression Systems**, **Hydrant Systems**, **Fire Alarm Systems** and other highly specialised fire fighting technologies.



This extensive product portfolio is built at the very forefront of technology and conforms to the highest global standards and carry a host of international certifications by world's top-notch quality agencies including - **BIS, EN3/ EN1866, LPCB, BSI, EU-MED, PED, VDS, ISO 9001 and UL** . Manufactured at the company's state-of the art production facility

in India, Ceasefire's fire fighting solutions are setting global benchmarks in quality. Best names across industry segments in India and other parts of the world have counted on us for their safety, including global giants, MNCs, Government Agencies, Railways, Airports, Military & Strategic Establishments. Totalling 500,000 customers. We've never let anyone down, ever.

OUR CERTIFICATIONS



FIRE EXTINGUISHERS

Core Range

Home & Car Extinguishers	09
ABC Powder Portable & Wheeled Extinguishers	11
CO ₂ Portable & Wheeled Extinguishers	13
Water Portable & Wheeled Extinguishers	15
Water Portable Extinguishers [Spray Model]	16
Foam Portable & Wheeled Extinguishers	17
Foam (Fluorine Free) Portable Extinguishers	18
Foam Portable Extinguishers [Spray Model]	19

Cartridge Range

ABC Powder Cartridge Portable & Wheeled Extinguishers	21
Water Cartridge Portable & Wheeled Extinguishers	23
Foam Cartridge Portable & Wheeled Extinguishers	24
Watermist Cartridge Portable Extinguishers	25
Foam mist Cartridge Portable Extinguishers	26

Special Application

Watermist Portable Extinguishers	28
Foammist Portable Extinguishers	29
Action-Pac [Portable Watermist & Foammist]	31
CAFS [Watermist Compressed Air Foam System - Low Pressure]	32
CAFS [Watermist Compressed Air Foam System - High Pressure]	33
QUAD [Watermist & Foammist Wheeled Extinguishers]	34
Tetraquad	35
Wet Chemical Portable Extinguishers	36
Wet Chemical Portable Extinguishers [Spray Model]	37
Fluoroketone (FK) Clean Agent Based Portable Extinguishers	38
HFC-227ea Clean Agent Based Portable Extinguishers	39
HFC-226fa Clean Agent Based Portable Extinguishers	40

Lithium Ion Battery Portable Extinguishers	41
B Plus Special Application [Class B] Extinguishers	42
Metal Fire Extinguishers	43

Automatics

Automatic Fire Extinguishers [Wall Mounted]	45
Automatic Fire Extinguishers [Ceiling Mounted]	46
Ceasefire Mini	48
Launcher [Extinguisher + Modular Suppression System]	49

EN Approved Premium Range

Home and Car Extinguishers	51
ABC Powder Portable & Wheeled Extinguishers	52
CO ₂ Portable & Wheeled Extinguishers	54
Water Portable & Wheeled Extinguishers	55
Foam Portable & Wheeled Extinguishers	56
Clean Agent Portable Extinguishers	57
Wet Chemical Portable Extinguishers	58
Lithium Ion Battery Portable Extinguishers	59
Lithium Ion Battery Compressed Air Fire Extinguishers	60
B Plus Special Application [Class B] Extinguishers	61
Watermist Portable Extinguishers	62
Foammist & Green-Foammist Portable Extinguishers	63
QUAD [Watermist, Foammist & Green-Foammist Wheeled Extinguishers]	64

Accessories

Fire Suits	66
Ceasefire Instalert	67
Strolleys	67
Flat Pack Tubular Stand- Chrome Finish	68
Signages	70
Flat Pack Trolleys	76
Flat Pack Fire Extinguisher Stand	78

SUPPRESSION SYSTEMS

In-Panel Tube Based Suppression System [CQRS]	83
Clean Agent Based Total Flooding System	85
Inert Gas Suppression System	87
Atom X	89
Automatic Fire Extinguishers [Wall Mounted]	91
Automatic Fire Extinguishers [Ceiling Mounted]	92
Ceasefire Mini	93
Launcher [Extinguisher + Modular Suppression System]	94
Server Quick Response System [SQRS]	95

Special Firefighting Accessories

Lancepro	96
Morph	97

HYDRANT SYSTEMS

CF-2000 Hydrant System	99
CF-3000 Hydrant System	100

KITCHEN SYSTEMS

ULtraX Kitchen Fire Suppression System [Wet Chemical based]	104
Commercial Kitchen Suppression System - Enviro [Watermist based]	105
Commercial Kitchen Suppression System - Ultra [Wet Chemical based]	106
Residential Kitchen Suppression System - Enviro [Watermist based]	107
Residential Kitchen Suppression System - Ultra [Wet Chemical based]	108

WATERMIST SUPPRESSION SYSTEMS

Nozzles	114
Generator Auto - Quell System	115
Transformer Auto - Quell System	116
Swift	117
Indoor Auto-Quell System	118

FIRE EXTINGUISHERS

IN THIS SECTION



Core Range



Cartridge Range



Special Application



Automatics



EN Approved Premium
Range



Accessories

A FIRE EXTINGUISHERS RANGE WITH INCREDIBLE LENGTH & DEPTH

Ceasefire's range of extinguishers offer an unmatched length and depth. From Core Range Extinguishers including ABC Powder, Water, Foam & CO₂ to Specialized Extinguishers including Clean Agent, Metal Fire, Watermist, Foammist, Compressed Air Foam, Wet Chemical and Extinguishers for domestic use, the range is the most comprehensive ever.

The length of the Ceasefire's range of extinguishers is complemented with an incredible depth too. The extinguishers are not only available in a wide variety of agents for unique application, but come in every size possible, ranging from the small sizes of 500gms, 1kg & 2kg to the Mid Segment of 4kg, 5kg, 6kg, 9kg and 12kg to the Plus sizes of 25kg, 50kg, 75kg and 250 Litres.



Widest Range of Extinguishers To Address Every Kind of Fire.

Ceasefire has a complete line of fire extinguishers and extinguishing agents to address the needs of any type of facility or application.

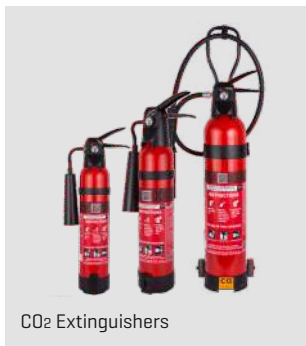

CO₂ Extinguishers

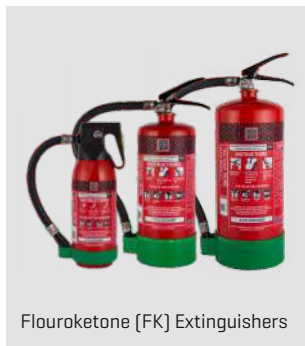

Flourocketone (FK) Extinguishers

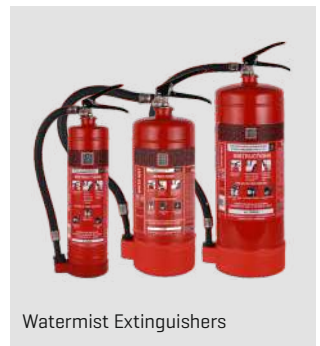

Watermist Extinguishers

THE MANUFACTURING EDGE

Our manufacturing facility is an ISO 9001 certified, state-of-the-art, backward-integrated production unit, with in-house container manufacturing, advance deep draw stations, in-house valve manufacturing, world-class paint shop and a highly

sophisticated & fully equipped quality test lab. The facility is fully compliant to the Factory Production Control (FPC) requirements of the highest global standards including EN3, EN1866, LPCB, BSI, MED, PED and OHSAS.



In-house design cell. Company owned manufacturing facility in Dehradun, India.



Testing labs equipped to carry out quality-standardized tests.



In-house valve manufacturing unit.



ISO certified production facility.



Advanced MIG CO2 welding station.



Tie-ups with the world's leading OEMs.



World-class paint shop that ensures superior product quality.



Quality certifications from world's best agencies.



EXTINGUISHERS PAR EXCELLENCE

Each of our extinguisher goes through the following mandatory tests:

- HPT Test:**
Hydrostatic Pressure Tested (HPT) with a pressure of 30kg/cm², which is three times the working pressure of an extinguisher.
- Inverted Beaker 24-hour Leak Test:**
Pressurised extinguishers are immersed in water for 24 hours with an inverted glass beaker placed on the neck. Any trace of air bubbles symbolizes leakage and the extinguisher is rejected.
- The Helium Leak Detection Test:**
The container is charged with 99% Nitrogen and a small amount of Helium is added. Helium being lighter than air leaks out even if there is slightest trace of leakage in any joint. If so, the extinguisher is rejected.



OUR EXTINGUISHERS ARE NOT JUST MANUFACTURED, THEY ARE ENGINEERED TO PERFECTION TO BECOME THE LIFESAVERS THEY ARE.

- Deep Draw Body:**
Portable extinguishers are manufactured using a state-of-the-art Deep Draw process ensuring minimal seams on the container body.
- MIG CO₂ Welding:**
Extinguishers are manufactured using advanced Motorized Metal Inert Gas Welding Technology giving them a much superior and stronger container body.
- Internal Epoxy Coating:**
Water/Foam/Wet chemical extinguishers are treated with internal epoxy coating that ensures no rust or corrosion.
- Treated for Longevity:**
Ceasefire extinguishers are chemically treated internally and externally to ensure durability & longevity.



Core Range of
Fire Extinguishers
Built for Speed, Power, and
Reliability.



HOME AND CAR FIRE EXTINGUISHERS (CLASSIC RANGE)

OVERVIEW:

Few minutes. That's all the time you have before a fire gets out of control. And the time you have to detect it, rush your family to safety and fight the fire. Packed with modern utilities, homes today have become extremely prone to fire. That's where Ceasefire's Home and Car fire extinguishers come in.

FEATURES:

- Most potent against Home & Car fires.
- Simplicity in design.
- Portable and easy to use.
- Colors to suit your home decor.
- State-of-the-art pressure gauge.
- Easy snap safety seal.
- World-class quality.

SIZES AVAILABLE:

- **Portable** :- 500 g, 1 Kg.



FIGHTS CLASS	CERTIFICATIONS
A B C ⚡	
	<small>IS 15683</small> <small>CMAI-8886112</small>
	<small>EN 13705</small> <small>LPCB Car Ref. 1325b</small> <small>KM666991</small>

Sizes	500 g	1 Kg
IS 15683 Fire Ratings	—	1A, 34B
BS EN-3 Fire Ratings	—	5A, 21B 5A, 34B



Scan code for Tech specs, Application areas and Product video.



HOME AND CAR FIRE EXTINGUISHERS (ART RANGE)

OVERVIEW:

Designed to match the aesthetics of your home, so that it's not tucked out of sight in a fire situation. Ceasefire's Designer range of extinguishers are art installations of fine steel and ink, crafted to meet international standards and designed to exceed them. Making these extinguishers true works of art. Art that saves property and lives.

FEATURES:

- Most potent against Home & Car fires.
- Simplicity in design.
- Portable and easy to use.
- Aesthetically pleasing designs to suit your home decor.
- State-of-the-art pressure gauge.
- Easy snap safety seal.
- World-class quality.

SIZES AVAILABLE:

- **Portable** :- 500 g, 1 Kg.

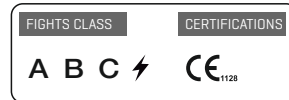

Scan code for Tech specs, Application areas and Product video.

ABC POWDER PORTABLE & WHEELED EXTINGUISHERS

OVERVIEW:

In environments such as schools, offices, hospitals & factories, the Ceasefire ABC Powder extinguisher is your safest bet. Mono Ammonium Phosphate paired with a simple, controllable discharge mechanism maximises the firefighting power and puts out the fire within seconds.

FEATURES:

- Fights Class A, B, C and Electrically started fires.
- Packed with 50% and 90% MAP concentration.
- State-of-the-art Pressure Gauge.
- Quick, powerful and reliable firefighting system.



SIZES AVAILABLE:

- **Portable** :- 2 Kg, 4 Kg, 6 Kg, 9 Kg.
- **Wheeled** :- 25 Kg, 50 Kg, 75 Kg.

FIGHTS CLASS	CERTIFICATIONS
A B C ⚡	  
	<small>IS 15683 DNV-9005112</small> <small>LPCB BS EN 3 LPCB Cert Ref: 13209</small> <small>CE 1128</small>

PORTABLE EXTINGUISHERS :

Sizes		2 Kg	4 Kg	6 Kg	9 Kg
MAP-50	IS 15683 Fire Ratings	2A, 70B	4A, 144B	6A, 183B	6A, 233B
	BS EN-3 Fire Ratings	8A, 70B	21A, 144B	27A, 183B	43A, 233B
MAP-90	IS 15683 Fire Ratings	3A, 70B	4A, 144B	6A, 183B	6A, 233B
	BS EN-3 Fire Ratings	13A, 55B	21A, 144B	27A, 183B	43A, 233B



ABC Powder MAP 50

ABC Powder MAP 90

Scan code for Tech specs, Application areas and Product video.



Scan code for Tech specs, Application areas and Product video.



WHEELED EXTINGUISHERS :

Sizes	25 Kg	50 Kg	75 Kg
IS 16018 Fire Ratings	20A, 233B	20A, 233B	20A, 233B



ABC Powder Wheeled



Scan code for Tech specs, Application areas and Product video.

CO₂ PORTABLE & WHEELED EXTINGUISHERS

OVERVIEW:

Ceasefire's sturdy and light CO₂ extinguisher is very effective in putting out fires in large spaces. Packed with tremendous power, it reduces the fire's oxygen supply, and brings the temperature down drastically, extinguishing the flames in seconds.

FEATURES:

- Fights Class B, C and Electrically started fires.
- Frost-free horn to dispense gas, removes risk of freeze burn.
- State-of-the-art Used/Ready indicator in selected range.

SIZES AVAILABLE:

- **Portable** :- 2 Kg, 4.5 Kg.
- **Wheeled** :- 6.5 Kg, 22.5 Kg.



Sizes	2 Kg	4.5 Kg	6.5 Kg	22.5 Kg
IS 15683 Fire Ratings	34B	55B	55B	—
IS 16018 Fire Ratings	—	—	—	113B
BS EN-3 Fire Ratings	34B	—	—	—



CO₂ Portable



CO₂ Wheeled

Scan code for Tech specs,
Application areas and
Product video.



Scan code for Tech specs,
Application areas and
Product video.



Water Extinguishers

Harness the Enormous Potential of Water



WATER PORTABLE & WHEELED EXTINGUISHERS (JET MODEL)

OVERVIEW:

Water has always been fire's deadliest foe. Ceasefire's Water extinguisher uses proprietary Stored Pressure Technology to deliver a high power throw of water. This ensures it fights fires effectively and enables the firefighter to maintain a safe distance from the flames.

FEATURES:

- Fights Class A fires.
- EPDM / Braided Rubber Hosepipe.
- Easy Snap Safety Pin.
- State-of-the-art Pressure Gauge in portable range.
- Powder Coated cylinder liner.
- Deep Drawn Body in the portable range.
- Extinguishant dispersed via specially designed Jet Nozzle.



SIZES AVAILABLE:

- **Portable** :- 6 Ltr, 9 Ltr.
- **Wheeled** :- 60 Ltr.



Sizes	6 Ltr	9 Ltr	60 Ltr
IS 15683 Fire Ratings	3A	4A	—
IS 16018 Fire Ratings	—	—	20A
BS EN-3 Fire Ratings	13A	21A	—



Water Portable

Water Wheeled

Scan code for Tech specs,
Application areas and
Product video.



Scan code for Tech specs,
Application areas and
Product video.



WATER PORTABLE EXTINGUISHERS (SPRAY MODEL)

OVERVIEW:

Water is a natural firefighting agent that helps bring down the temperature of the fire and the area around it. Ceasefire's Water Spray model extinguishers can be used on Class A, F, and Electrically started fires, making them more effective against the fire.

FEATURES:

- Fights class A, F & Electrically Started Fires.
- EPDM/Braided Rubber Hosepipe.
- Easy Snap Safety Pin.
- State-of-the-art Pressure Gauge.
- Epoxy polyester powder coated internal container lining.
- Deep Drawn cylinder construction.
- Extinguishant dispersed via specially designed Spray Nozzle.
- Suitable for use on live electrical equipment upto 1000 V from a distance of 1 meter.



SIZES AVAILABLE:

- **Portable :-** 6 Ltr, 9 Ltr.

Sizes	6 Ltr	9 Ltr
IS 15683 Fire Ratings	3A	4A



Scan code for Tech specs, Application areas and Product video.

FOAM PORTABLE & WHEELED EXTINGUISHERS (ASPIRATING MODEL)

OVERVIEW:

Fire needs oxygen to grow. Without it, even the largest fires die out in minutes. Ceasefire's Foam extinguisher exploits this weakness by discharging a mechanical foam that blankets the flames and cuts off the oxygen supply. It's what we like to call simple and effective firefighting.

FEATURES:

- Fights Class A and B fires.
- State-of-the-art Pressure Gauge in portable range.
- Deep Drawn Body in the portable range.
- Stored Pressure technology for more effective firefighting.
- Squeeze Grip mechanism for quick and easy use.
- Epoxy polyester powder coated internal container lining.



SIZES AVAILABLE:

- **Portable** :- 3 Ltr, 6 Ltr, 9 Ltr.
- **Wheeled** :- 60 Ltr.

FIGHTS CLASS

A B

CERTIFICATIONS



Sizes	3 Ltr	6 Ltr	9 Ltr	60 Ltr
IS 15683 Fire Ratings	2A, 55B	3A, 144B	4A, 233B	—
IS 16018 Fire Ratings	—	—	—	20A, 233B
BS EN-3 Fire Ratings	—	13A, 144B	21A, 233B	—



Foam Portable

Foam Wheeled

Scan code for Tech specs,
Application areas and
Product video.



Scan code for Tech specs,
Application areas and
Product video.



FOAM (FLUORINE FREE) PORTABLE EXTINGUISHERS (ASPIRATING MODEL)

OVERVIEW:

Ceasefire's Fluorine Free Foam Extinguishers work by cutting off a fire's oxygen supply, which is essential for its survival. The foaming agent blankets the flames and cuts off the oxygen supply. Being fluorine free these extinguishers provide an environment friendly foam based extinguishing agent option. While they are effective against Class B fires, involving flammable liquids like oil and petrol, the agent is also super effective to address the risk of class A fires.

Ceasefire's Fluorine Free Foam Extinguishers use the squeeze grip mechanism, making them faster and easier to use. The proprietary stored pressure technology also delivers high power throw, making these extinguishers extremely effective.

FEATURES:

- Fights Class A and B fires.
- Long and flexible hose pipe aids simplicity in handling.
- Easy to read pressure gauge for ease of monitoring.
- EPDM Rubber Hose Pipe:
- 6 year Warranty.
- BSI tested, PED, and ISO 9001 certified.



FIGHTS CLASS	CERTIFICATIONS
A B	 

SIZES AVAILABLE:

- **Portable** :- 3 Ltr, 6 Ltr, 9 Ltr.

Sizes	3 Ltr	6 Ltr	9 Ltr
IS 15683 Fire Ratings	2A, 55B	3A, 113B	4A, 183B



Scan code for Tech specs, Application areas and Product video.

FOAM PORTABLE EXTINGUISHERS [SPRAY MODEL]

OVERVIEW:

The quickest way to kill a fire is by limiting the oxygen supply in the vicinity. Ceasefire's Foam Spray model extinguishers forms a foam blanket, cutting down on the oxygen supply. It works on Class A, B, F, and Electrically started fires.

FEATURES:

- Fights class A, B, F & Electrically started fires.
- Deep Drawn cylinder construction.
- Stored Pressure technology for more effective firefighting.
- Squeeze Grip mechanism for quick and easy use.
- Epoxy polyester powder coated internal container lining.
- Equipped with Schraeder Valve and Pressure Relief Valve.
- Suitable for use on live electrical equipment upto 1000 V from a distance of 1 meter.



SIZES AVAILABLE:

- **Portable :-** 6 Ltr, 9 Ltr.

Sizes	6 Ltr	6 Ltr	9 Ltr
IS 15683 Fire Ratings	3A	3A	4A



Scan code for Tech specs, Application areas and Product video.



Cartridge Range of Fire Extinguishers

Firepower, On The Spot



ABC POWDER CARTRIDGE TYPE PORTABLE & WHEELED FIRE EXTINGUISHERS

OVERVIEW:

Ceasefire's ABC Powder Cartridge kicks into action when you need them, where you need them. Being one of the most versatile extinguishing agents, Mono Ammonium Phosphate expands and forms a thin layer on top of the surface, controlling the fire and stopping re-ignition. The spot pressure technology makes the extinguishers highly safe for all types of spaces as the pressure is created only at the time of fire fighting.

FEATURES:

- Fights Class A, B, C and electrically started fires.
- Requires no prior training.
- Works quickly without wasting any extinguishing agent.
- Spot pressure technology makes extinguishers safe and reliable.
- Easy-to-use with quick activation.

SIZES AVAILABLE:

- **Portable** :- 4 Kg, 6 Kg, 9 Kg, 12 Kg.
- **Wheeled** :- 25 Kg, 50 Kg, 75 Kg.



Sizes	4 Kg	6 Kg	9 Kg	12 Kg
IS 15683 Fire Ratings	4A, 144B	6A, 183B	6A, 183B	—
BS EN-3 Fire Ratings	—	—	—	55A, 233B



ABC Powder Portable

Scan code for Tech specs, Application areas and Product video.



WHEELED EXTINGUISHERS :

Sizes	25 Kg	50 Kg	75 Kg
IS 16018 Fire Ratings	20A, 233B	20A, 233B	20A, 233B



Scan code for Tech specs, Application areas and Product video.

WATER CARTRIDGE TYPE PORTABLE & WHEELED FIRE EXTINGUISHERS

OVERVIEW:

These cartridge-type extinguishers employ the most efficient firefighting solution known to man, water. With its massive cooling power of 2.6 MW per litre per second, water kills even the largest of fires in minutes.

In the Ceasefire Water-based Cartridge, water is mixed with CO2 from the cartridge. When it comes in contact with a fire, the water turns into steam, cooling the area, cutting off the oxygen supply and killing the flames

FEATURES:

- Fights Class A, B, C and electrically started fires.
- Requires no prior training.
- Works quickly without wasting any extinguishing agent.
- Spot pressure technology makes extinguishers safe and reliable.
- Easy-to-use with quick activation.

SIZES AVAILABLE:

- **Portable** :- 6 Ltr, 9 Ltr.
- **Wheeled** :- 60 Ltr.



FIGHTS CLASS	CERTIFICATIONS
A	IS 15683 IS 16018 BS EN-3 CE 1128

Sizes	6 Ltr	9 Ltr	60 Ltr
IS 15683 Fire Ratings	3A	4A	—
IS 16018 Fire Ratings	—	—	20A
BS EN-3 Fire Ratings	—	21A	—

Water Portable

Scan code for Tech specs, Application areas and Product video.



Water Wheeled

Scan code for Tech specs, Application areas and Product video.



FOAM CARTRIDGE TYPE PORTABLE & WHEELED FIRE EXTINGUISHERS

OVERVIEW:

These cartridge-type extinguishers use foam to take on Class A and B fires. The Ceasefire Foam Cartridge is also equipped with a specialised nozzle or aerator that produces a thick foam that coats the surface of the fire and cuts off the oxygen supply. This makes them the perfect choice for chemical industries that use flammable liquids.



FEATURES:

- Fights Class A, B, C and electrically started fires.
- Requires no prior training.
- Works quickly without wasting any extinguishing agent.
- Spot pressure technology makes extinguishers safe and reliable.
- Easy-to-use with quick activation.

SIZES AVAILABLE:

- **Portable** :- 6 Ltr, 9 Ltr.
- **Wheeled** :- 60 Ltr.



FIGHTS CLASS	CERTIFICATIONS
A B	IS 15683   <small>CHL 8886112</small>

Sizes	6 Ltr	9 Ltr	60 Ltr
IS 15683 Fire Ratings	3A, 144B	4A, 233B	—
IS 16018 Fire Ratings	—	—	20A, 233B



Foam Portable



Foam Wheeled



Scan code for Tech specs, Application areas and Product video.



Scan code for Tech specs, Application areas and Product video.

WATERMIST CARTRIDGE TYPE PORTABLE FIRE EXTINGUISHERS

OVERVIEW:

Ceasefire’s Watermist Cartridge is powered by revolutionary Watermist technology, which harnesses the massive cooling power of water and multiplies it by 400. The Ceasefire Watermist Cartridge is the first of its kind extinguisher to offer Watermist technology or Foammist technology in an ultra-safe cartridge extinguisher.

The CO2 from the cartridge combines with the water in the container, breaking down into a fine mist of 54 microns in the mist generator nozzle. After coming into contact with fire, this fine watermist turns into steam, cooling down the area and killing the fire without causing any collateral damage to machinery.

FEATURES:

- Fights Class A, B, C and electrically started fires.
- Requires no prior training.
- Works quickly without wasting any extinguishing agent.
- Spot pressure technology makes extinguishers safe and reliable.
- Easy-to-use with quick activation.



FIGHTS CLASS	CERTIFICATIONS
A F ⚡	IS 15683 CE 1128

SIZES AVAILABLE:

- **Portable :-** 3 Ltr, 6 Ltr.

Sizes	3 Ltr	6 Ltr
IS 15683 Fire Ratings	2A, 25F	3A, 75F



Scan code for Tech specs, Application areas and Product video.



FOAMMIST CARTRIDGE TYPE PORTABLE FIRE EXTINGUISHERS

OVERVIEW:

This cartridge extinguisher uses the powerful Foammist extinguishing agent to take on the biggest of fires. Foammist is a revolutionary technology wherein the power of foam is multiplied hundreds of times over.

In Ceasefire's Foammist-based Cartridge the foam in the container combines with CO2 in the cartridge, and is released through the mist generator nozzle as Foammist. Under 80 microns in size, this mist envelops over the fire, cutting off the oxygen supply and putting out the fire.



FEATURES:

- Fights Class A, B, C and electrically started fires.
- Requires no prior training.
- Works quickly without wasting any extinguishing agent.
- Spot pressure technology makes extinguishers safe and reliable.
- Easy-to-use with quick activation.

SIZES AVAILABLE:

- **Portable :-** 3 Ltr, 6 Ltr.



FIGHTS CLASS	CERTIFICATIONS
A B F ⚡	1015589   DMV-8886112

Sizes	3 Ltr	6 Ltr
IS 15683 Fire Ratings	2A, 55B, 25F	3A, 89B, 75F



Scan code for Tech specs, Application areas and Product video.

Special Application Extinguishers

To Protect High Risk
Spaces.



WATERMIST PORTABLE FIRE EXTINGUISHERS

OVERVIEW:

The cleanest extinguishing agent known to man - Water. These extinguishers use stored pressure technology, advanced rotors and specially designed nozzles to generate an ultra fine spray of water called Watermist. Blocking the entry of oxygen in the fire zone and bringing down the temperature to below combustion levels. Enter the Ceasefire watermist fire fighting systems that increase the power of water 400 times over.

FEATURES:

- Fights class A, F and Electrically started fires.
- Green extinguishing technology.
- Low water usage.
- Stainless steel containers.
- Environment friendly.
- Suitable for use on live electrical equipment upto 1000 V from a distance of 1 meter.



SIZES AVAILABLE:

- **Portable** :- 2 Ltr, 3 Ltr, 6 Ltr, 9 Ltr.



Sizes	2 Ltr	3 Ltr	6 Ltr	9 Ltr
IS 15683 Fire Ratings	1A, 25F	2A, 25F	3A, 75F	4A, 75F
BS EN-3 Fire Ratings	5A, 25F	—	13A, 75F	21A, 75F



Scan code for Tech specs, Application areas and Product video.

FOAMMIST PORTABLE FIRE EXTINGUISHERS

OVERVIEW:

Ceasefire Foammist extinguisher range, harness the combined power of the revolutionary watermist technology and foam in its range of extinguishers. The foam mist fire fighting system forms a foam blanket on top of the fire, thereby eliminating entry of oxygen and killing the fire instantly.

FEATURES:

- Fights class A, B, F and Electrically started fires.
- Green extinguishing technology.
- Low water usage.
- Highly safe and effective.
- Environment-friendly.
- Suitable for use on live electrical equipment upto 1000 V from a distance of 1 meter.

SIZES AVAILABLE:

- **Portable :-** 2 Ltr, 6 Ltr.



FIGHTS CLASS

A B F ⚡

CERTIFICATIONS



IS 15683



LPCB



CE 1128

Sizes	2 Ltr	6 Ltr
IS 15683 Fire Ratings	1A, 55B, 25F	3A, 144B, 75F
BS EN-3 Fire Ratings	5A, 55B, 25F	13A, 144B, 40F



Scan code for Tech specs, Application areas and Product video.



Widest Range of
**Watermist
Extinguisher**
To Suit Every Kind of
Premises.



ACTION-PAC (PORTABLE WATERMIST AND FOAMMIST)

OVERVIEW:

Presenting the Ceasefire Action-Pac extinguisher, the first of its kind in the world. Powered by 100% Green Watermist, this backpack & trolley mounted fire extinguisher is packed with immense fire fighting power and can easily be carried to the scene of the fire to battle the flames.

FEATURES:

- Fights class A, B and Electrically started fires.
- 1 minute of continuous discharge, without flooding.
- Creates a fine mist of under 80 microns.
- Environment-friendly.
- Specially designed Discharge Gun employs either spray or jet mode.
- Thermal shock proof.
- Built-in Trolley or Backpack.

SIZES AVAILABLE:

- **Portable** :- 13 Ltr.



FIGHTS CLASS	CERTIFICATIONS
A B ⚡	CE ₁₁₂₈

Sizes	13 Ltr [Watermist]	13 Ltr [Foammist]
BS EN-3 Fire Ratings	27A	43A, IVB



Scan code for Tech specs, Application areas and Product video.



CAFS [WATERMIST COMPRESSED AIR FOAM SYSTEM - LOW PRESSURE]

OVERVIEW:

Ceasefire's Compressed Air Foam System uses a specially designed discharge gun that expels approximately 100-micron sized droplets with a kinetic force strong enough to overcome the fire's convection currents. The watermist turns into steam, evaporates, and stops the fire from spreading. The foam component has a blanketing effect on the fire. The system is safe to use on Class B fires like petrol, diesel, and electrically started fires—two areas where traditional water applications would either spread the fire or cause an electrical shock.

FEATURES:

- Fights class A, B and Electrically started fires.
- Dual phase extinguishing gun with an adjustable nozzle.
- Pure water based green extinguishing technology.
- Thermal shock proof.
- No collateral damage.



SIZES AVAILABLE:

- **Portable** :- 9 Ltr.
- **Wheeled** :- 50 Ltr.

bsi.
Tested



Sizes	9 Ltr	9 Ltr (Special Foam)	9 Ltr (with Backpack)	50 Ltr	50 Ltr (Special Foam)	50 Ltr (with Trolley)
BS EN-3 Fire Ratings	27A/55A, 233B	43A, 233B	27A, 233B	—	—	—
BS EN-1866 Fire Ratings	—	—	—	55A, IIB	43A, IIB	21A, IIB



Scan code for Tech specs, Application areas and Product video.

CAFS (WATERMIST COMPRESSED AIR FOAM SYSTEM - HIGH PRESSURE)

OVERVIEW:

Ceasefire Compressed Air Foam System features a high-technology gun that breaks foam into minuscule droplets. These droplets are then delivered through micro-nozzles with a high degree of dispersion onto the flames, allowing you to fight even very large fires successfully. This key process stops the fire from spreading and eliminates post-fire collateral damage such as flooding. The foam also acts as a perfect barrier against thermal radiation, giving increased protection to the firefighter.

FEATURES:

- Fights class A, B and Electrically started fires.
- Dual phase extinguishing gun with an adjustable nozzle.
- Pure water based green extinguishing technology.
- Thermal shock proof.
- No collateral damage.



SIZES AVAILABLE:

- **Portable** :- 10 Ltr.
- **Wheeled** :- 50 Ltr.

bsi.
Tested



Sizes	10 Ltr	10 Ltr (Special Foam)	10 Ltr (with Backpack)	50 Ltr	50 Ltr (Special Foam)	50 Ltr (with Trolley)
BS EN-3 Fire Ratings	55A, 233B	—	34A, 233B	—	—	—
BS EN-1866 Fire Ratings	—	—	—	55A, IVB	—	21A, IVB



Scan code for Tech specs, Application areas and Product video.



QUAD (WATERMIST & FOAMMIST WHEELED EXTINGUISHERS)

OVERVIEW:

Ceasefire Quad brings together the efficiency of a fire extinguisher with the power of a hydrant system. It breaks water down into a fine mist of under 80 microns and covers a large surface area, reducing the temperature to below combustion levels. Meant for areas where fire risk is huge, or where large amounts of combustible materials are stored, the trolley-mounted Quad can be taken anywhere with ease.

FEATURES:

- Fights class A, B, C, F and Electrically started fires.
- Green extinguishing technology.
- Low water usage.
- Highly safe and effective.
- Environment-friendly.
- Suitable for use on live electrical equipment upto 1000V from a distance of 1 meter.

SIZES AVAILABLE:

- **Watermist** :- 20 Ltr, 45 Ltr, 90 Ltr.
- **Foammist** :- 20 Ltr, 45 Ltr, 90 Ltr.

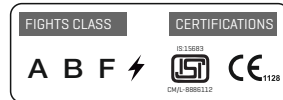

Sizes		20 Ltr	45 Ltr	90 Ltr
Watermist	IS 16018 Fire Ratings	10A	10A	20A
Foammist	IS 16018 Fire Ratings	10A, 233B	15A, 233B	20A, 233B



Scan code for Tech specs, Application areas and Product video.

TETRAQUAD

OVERVIEW:

Ceasefire TetraQuad is a mini tender on wheels. A power-packed Watermist + Foam system that quadruples the firefighting power by four. TetraQuad's firefighting might come from its four state-of-the-art multi-rotors working in sync with each of the four 62.5 ltr containers [totaling 250 ltrs in capacity].

FEATURES:

- Works on class A and B fires.
- Low pressure, safe technology.
- 4 Cylinders, Massive Firefighting.
- Easy-to-use with quick activation.
- Environment-friendly.
- Two modes of firefighting - Jet & Spray Mode.

SIZES AVAILABLE:

- **Wheeled** :- 250 Ltr [water & water + Foam].



FIGHTS CLASS	CERTIFICATIONS
A B	CE ₁₁₂₈



Scan code for Tech specs, Application areas and Product video.



WET CHEMICAL PORTABLE EXTINGUISHERS

OVERVIEW:

In commercial kitchens, the liberal use of fire and the presence of combustible substances make it easy for a fire to flare up. Designed to fight kitchen oil and fat fires, Ceasefire's Wet Chemical fire extinguisher uses an environmental friendly foaming agent that blankets the flames, cuts off the supply of oxygen and cools the oil to below the self-ignition point.

FEATURES:

- Fights class A, F and Electrically started fires.
- Bio-degradable extinguishing agent.
- Reduces risk of re-ignition.
- Suitable for use on live electrical equipment upto 1000 V from a distance of 1 meter.
- Epoxy polyester powder coated internal container lining.
- Equipped with Schraeder Valve and Pressure Relief Valve.

SIZES AVAILABLE:

- **Portable :-** 3 Ltr, 6 Ltr, 9 Ltr.



Sizes	3 Ltr	6 Ltr	9 Ltr
IS 15683 Fire Ratings	2A, 25F	3A, 75F	—
BS EN-3 Fire Ratings	—	13A, 75F	21A, 75F



Scan code for Tech specs, Application areas and Product video.

WET CHEMICAL PORTABLE EXTINGUISHERS (SPRAY MODEL)

OVERVIEW:

Ceasefire's Wet Chemical Spray model extinguishers use an environmentally friendly foaming agent that blankets the flames, cuts off the supply of oxygen, cools the oil to below the self-ignition point and reduces the risk of re-ignition. It can be used on Class A, F, and electrically started fires.

FEATURES:

- Fights class A, F and Electrically started fires.
- Biodegradable extinguishing agent.
- Reduces risk of re-ignition.
- Suitable for use on live electrical equipment up to 1000 V from a distance of 1 metre.
- Equipped with Schrader Valve and Pressure Relief Valve.



SIZES AVAILABLE:

- **Portable :-** 3 Ltr, 6 Ltr, 9 Ltr.

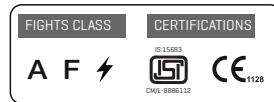

Sizes	3 Ltr	6 Ltr	9 Ltr
IS 15683 Fire Ratings	2A, 25F	3A, 75F	4A, 75F



Scan code for Tech specs, Application areas and Product video.



FLUOROKETONE (FK) CLEAN AGENT BASED PORTABLE EXTINGUISHERS

OVERVIEW:

Safe to use on all your sensitive equipment, the Fluoroketone (FK) Clean Agent Extinguisher brings you the added benefit of being the world's most advanced, and by far the most eco-friendly extinguisher. Fluoroketone (FK) Clean Agent Extinguishers leave no residue, pack in mega power and are absolutely safe for use on any sensitive electronic equipment.

They have zero ODP (Ozone Depletion Potential) and are the obvious choice of concerned corporates worldwide. They are extremely lightweight, yet packed with tremendous power and throw, to penetrate past even the finest grills and meshes.

FEATURES:

- Fights class A, B, C, and electrically started fires.
- Zero collateral damage and residue-free.
- Easy-to-read Pressure Gauge for ease of monitoring.
- Safe Low-Pressure Technology that does not displace oxygen in the fire zone.
- Zero Ozone Depletion Potential (ODP) and <1 ODP.

SIZES AVAILABLE:

- **Portable** :- 2 Kg, 4 Kg, 6 Kg.

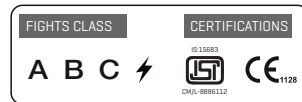

Sizes	2 Kg	4 Kg	6 Kg
IS 15683 Fire Ratings	1A, 21B	1A, 34B	2A, 55B



Scan code for Tech specs, Application areas and Product video.

HFC-227ea CLEAN AGENT BASED PORTABLE EXTINGUISHERS

OVERVIEW:

Specially created to safeguard valuable life and equipment, the Ceasefire HFC 227ea Clean Agent extinguishers safeguard life and property. What's more, since HFC 227ea is green in nature, this gas-based extinguishing agent ensures that the fire is put out without causing any collateral damage to the premises, expensive equipment and the Earth.

FEATURES:

- Works on class A, B, C fires and fires involving electrically-charged devices.
- Ozone, Environment-Friendly.
- Zero collateral damage and residue-free.
- Easy-to-read Pressure Gauge for ease of monitoring.

SIZES AVAILABLE:

- **Portable** :- 2 Kg, 4 Kg, 6 Kg.

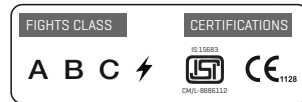

Sizes	2 Kg	4 Kg	6 Kg
IS 15683 Fire Ratings	1A, 21B	1A, 34B	2A, 55B



Scan code for Tech specs, Application areas and Product video.



HFC-236fa CLEAN AGENT BASED PORTABLE EXTINGUISHERS

OVERVIEW:

Introducing the HFC 236fa Clean Agent Extinguisher – the world's most advanced and eco-friendly fire suppressant. Safe to use on all your sensitive equipment, this extinguisher packs mega power without leaving any residue. Say goodbye to worries about damaging your electronics because the HFC 236fa Clean Agent Extinguisher is absolutely safe to use on any electronic device. And with zero Ozone Depletion Potential, it is the obvious choice for concerned corporates worldwide. This powerful extinguisher can penetrate even the finest grills and meshes with ease.

FEATURES:

- Fights class A, B, C, and electrically started fires.
- Zero collateral damage and residue-free.
- Easy-to-read Pressure Gauge for ease of monitoring.
- Safe Low-Pressure Technology that does not displace oxygen in the fire zone.
- Zero Ozone Depletion Potential [ODP] and <1 ODP.

SIZES AVAILABLE:

- **Portable** :- 2 Kg, 4 Kg, 6 Kg.



Sizes	2 Kg	4 Kg	6 Kg
IS 15683 Fire Ratings	1A, 21B	1A, 34B	2A, 55B
BS EN-3 Fire Ratings	21B	34B	34B



Scan code for Tech specs, Application areas and Product video.

LITHIUM ION BATTERY PORTABLE EXTINGUISHERS

OVERVIEW:

Lithium batteries are becoming a more common fire hazard as the number of consumer and industrial products fueled by lithium-ion batteries expands. They are becoming popular because of the power they can create at a given weight and size as compared to conventional lead-type batteries. Because of their high-temperature sensitivity, they are inherently flammable. Due to heat, these battery packs degrade much faster than they would normally.

Lithium-ion battery packs can catch fire and cause extensive damage if they malfunction.

FEATURES:

- Effective on Class A and B fires also.
- Environment friendly.
- No PFAS/PFOS.
- Non-toxic.
- Specialised gel agent.
- 100% biodegradable.

SIZES AVAILABLE:

- **Portable :-** 2 Ltr, 3 Ltr, 6 Ltr, 9 Ltr.



FIGHTS CLASS

A B 

CERTIFICATIONS

CE ₁₁₂₈

Sizes	2 Ltr	3 Ltr	6 Ltr	9 Ltr
Fire Ratings	1A, 34B	1A, 55B	2A, 113B	3A, 183B
BS EN-3 Fire Ratings	5A, 34B	8A, 55B	13A, 113B	21A, 183B
Battery Fire Ratings	350 W/h	600 W/h	900 W/h	1200 W/h



Scan code for Tech specs, Application areas and Product video.



B PLUS SPECIAL APPLICATION (CLASS B) EXTINGUISHERS

OVERVIEW:

Ceasefire's B Plus quadruples the power of a conventional extinguisher! It's the perfect extinguisher for petrol stations and petrochemical plants. The Ceasefire B Plus is ideal for Class B and C fires involving gasoline, alcohol, industrial chemicals, and more. When activated, its unique powder splits into four, covering a large surface area. So when faced with a high risk of class B fires like petrol, diesel, etc. You go for B Plus.

FEATURES:

- Fights Class B, C and Electrically started fires.
- Unique powder splits into four upon activation.
- High power agent throw covers a huge surface area.
- Equipped with Schraeder Valve and Pressure Relief Valve.

SIZES AVAILABLE:

- **Portable :-** 1Kg, 2 Kg, 4 Kg, 6 Kg, 9 Kg.



Sizes	1 Kg	2 Kg	4 Kg	6 Kg	9 Kg
IS 15683 Fire Ratings	34B	89B	233B	233B	233B
BS EN-3 Fire Ratings	—	89B	233B	233B	233B



Scan code for Tech specs, Application areas and Product video.

METAL FIRE EXTINGUISHERS

OVERVIEW:

Industries that work with metals such as magnesium, potassium, sodium, titanium, uranium and calcium are at a high risk of fire. Using the wrong extinguishing agent in this case may cause more damage. The Ceasefire SPM-TEC and SPM-PYRO are ideal combatants against fires involving heavy metals, alkali metals and their alloys. They are powerful enough to stop metal fires of up to 5000°C. Dead in their tracks. Within minutes.

FEATURES:

- Works on class A and B fires.
- Low pressure, safe technology.
- 4 Cylinders, Massive Firefighting.
- Easy-to-use with quick activation.
- Environment-friendly.
- Two modes of firefighting - Jet & Spray Mode.

SIZES AVAILABLE:

- **SPM TEC** :- 4 Kg, 6 Kg, 9 Kg
- **SPM PYRO** :- 4 Kg, 6 Kg, 9 Kg



Metal Fire Extinguishers [SPM - Tec]

Scan code for Tech specs,
Application areas and
Product video.



Metal Fire Extinguishers [SPM - Pyro]



Scan code for Tech specs,
Application areas and
Product video.



Automatic Extinguishers

24X7 Automated Fire Protection



CEASE FIRE
FIRE EXTINGUISHING
6 KG ABC POWDER
27A 1838
1. PULL OUT
2. AIM THE FIRE AND FROM A DISTANCE THROW THE EXTING

POWDER
EN3

CEASE FIRE

AUTOMATIC EXTINGUISHERS (WALL MOUNTED)

OVERVIEW:

Ceasefire's Wall Mounted Automatic Fire Extinguisher addresses two simple problems; first of fire safety and second of space crunch. Being an automatic extinguisher it is ideal for spaces like boats and engine compartments that are not just prone to fire but also have limited space, where installing an extinguisher can be a challenge.

FEATURES:

- Comes in option of Fluoroketone and Powder.
- Clean agent Fluoroketone based extinguishers do not fall under the ambit of F-gas regulations.
- Works on all classes of fire.
- Automatic detection and suppression.
- Comes with a secure mounting bracket for direct installation on the wall.
- Optional flexible mounting bracket that enables optimal positioning of the extinguisher in the risk zone.

SIZES AVAILABLE:

- **ABC Powder** :- 1 Kg, 2 Kg, 4 Kg, 6 Kg, 9 Kg.
- Fluoroketone [FK]** :- 1 Kg, 1.5 Kg, 2 Kg, 2.5 Kg, 4 Kg, 6 Kg, 9 Kg.



FIGHTS CLASS

CERTIFICATIONS

A B C ⚡

CE₁₁₂₈

TELESCOPING WALL MOUNTING BRACKET

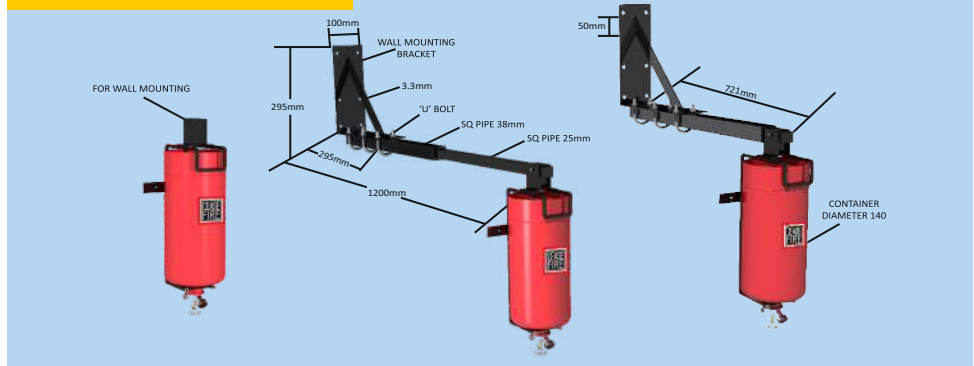

Fluoroketone Extinguishers [FK-5-1-12]

ABC Powder Extinguishers

Scan code for Tech specs,
Application areas and
Product video.



Scan code for Tech specs,
Application areas and
Product video.



AUTOMATIC EXTINGUISHERS (CEILING MOUNTED)

OVERVIEW:

There are areas in a workplace that contain highly flammable materials with little or no human traffic. Here, the chances of fire going undetected are high. Ceasefire's Ceiling mounted extinguisher detects the rising temperature of the area and activates automatically, even when there's no one around, ensuring that the fire is brought under control early and efficiently.

FEATURES:

- Fights class A, B, C and Electrically started fires.
- Automatic discharge mechanism.
- Rigid ceiling mount.
- Comes in option of Clean Agent and Powder.
- Green Technology.

SIZES AVAILABLE:

- **ABC Powder** :- 5 Kg, 10 Kg.
- **Clean Agent** :- 1 Kg, 1.5 Kg, 2 Kg, 4 Kg, 5 Kg, 6 Kg, 9 Kg, 10 Kg, 15 Kg.



bsi.

Tested



Smart. Intelligent.
Automated Fire Protection.



Clean Agent Extinguishers



Scan code for Tech specs,
Application areas and
Product video.

ABC Powder Extinguishers



Scan code for Tech specs,
Application areas and
Product video.



Ceasefire Mini

The Biggest, Smallest
Firefighter.



CEASEFIRE MINI

OVERVIEW:

The Mini is Ceasefire's state-of-the-art micro-environment suppression system. Palm-sized, it sits snugly inside small enclosed spaces that are vulnerable to fire. When the temperature of the micro-environment exceeds a preset limit, the Mini swings into action and extinguishes the fire. Servers, fuse boxes; the Mini fits anywhere, and protects everywhere.

FEATURES:

- Fights all classes of fire.
- Self-activated and easy to install.
- No power supply required.
- Heat-sensitive glass bulb acts as a heat sensor and actuator.
- Mini is based on an environment friendly clean agents.

SIZES :

- **Adaptive / Intuitive** :- 100 gm, 200 gm, 300 gm, 400 gm, 500 gm.



bsi.

Tested



TYPES OF MINI:

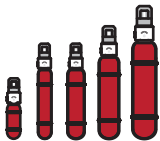

Intuitive System

The Mini Intuitive System is a direct suppression system, which protects the micro-environment from enclosed area inside. Place it inside, or attach it to the inner wall of the micro-environment, and the Mini is ready to protect.

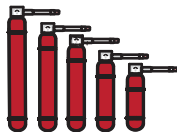
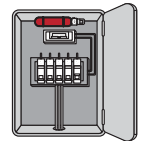

Adaptive System

The Mini Adaptive System is an indirect suppression system designed for those micro-environments which are too small to even accommodate a Mini, let alone other firefighting systems. In this case, the Mini container is installed on the outside, with its heat-sensitive glass bulb inside the micro-environment.

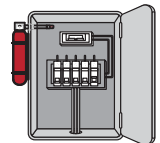

Mini - Intuitive



Scan code for Tech specs, Application areas and Product video.

Mini - Adaptive



Scan code for Tech specs, Application areas and Product video.

LAUNCHER (EXTINGUISHER + MODULAR SUPPRESSION SYSTEM)

OVERVIEW:

This one-of-a-kind extinguisher can be used to fight a fire manually, on auto-pilot when it senses a rise in temperature, or be thrown into the flames. This makes it a revolutionary extinguisher that ensures no fire ever goes undetected or unaddressed. Its biggest advantage is that it eliminates the need for a firefighter to go anywhere near the fire. A huge benefit, especially in case of a large blaze.

FEATURES:

- Fights class A, B, C and Electrically started fires.
- Unique Discharge Mechanism.
- Self-Actuation.
- Quick and effective.
- Two Heat Sensors.
- Extinguisher + Modular Suppression System.

SIZES AVAILABLE:

- **Portable** :- 4 Kg, 6 Kg, 9 Kg.



bsi.
Tested

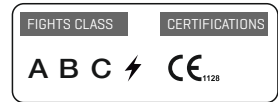

Sizes	4 Kg	6 Kg	9 Kg
IS 15683 Fire Ratings	4A, 144B	6A, 183B	6A, 233B
BS EN-3 Fire Ratings	21A, 144B	27A, 183B	43A, 233B

Extinguisher + Suppression
Power Packed into One



Scan code for Tech specs, Application areas and Product video.



Premium Range Of **EN APPROVED** Fire Extinguishers



HOME AND CAR FIRE EXTINGUISHERS (CLASSIC RANGE)

OVERVIEW:

Ceasefire's range of Home & Car extinguishers take the guesswork and confusion out of choosing an extinguisher and save valuable time. Mono Ammonium Phosphate being a potent firefighting agent maximises the fire fighting power. These extinguishers are easier to use than others because of their lightweight 'point and shoot' design.

FEATURES:

- Most potent against Home & Car fires.
- Simplicity in design.
- Portable and easy to use.
- Colors to suit your home decor.
- State-of-the-art pressure gauge.
- Easy snap safety seal.
- World-class quality.

SIZES AVAILABLE:

- Portable :- 1 Kg.



Sizes	1 Kg [Map 50]	1 Kg [Map 90]
BS EN-3 Fire Ratings	5A, 34B	5A, 21B



Scan code for Tech specs, Application areas and Product video.



ABC POWDER PORTABLE & WHEELED EXTINGUISHERS

OVERVIEW:

In environments such as schools, offices, hospitals & factories, the Ceasefire ABC Powder extinguisher is your safest bet. Mono Ammonium Phosphate paired with a simple, controllable discharge mechanism maximises the firefighting power and puts out the fire within seconds.

FEATURES:

- Fights Class A, B, C and Electrically started fires.
- Packed with 50% and 90% MAP concentration.
- State-of-the-art Pressure Gauge.
- Quick, powerful and reliable firefighting system.
- Equipped with Schraeder Valve and Pressure Relief Valve [available only in portable range].

SIZES AVAILABLE:

- **Portable** :- 2 Kg, 4 Kg, 6 Kg, 9 Kg, 12 Kg.
- **Wheeled** :- 25 Kg, 50 Kg, 100 Kg.



PORTABLE EXTINGUISHERS :

Sizes		2 Kg	4 Kg	6 Kg	9 Kg	12 Kg
MAP-50	BS EN-3 Fire Ratings	8A, 70B	21A, 144B	27A, 183B	43A, 233B	55A, 233B
MAP-90	BS EN-3 Fire Ratings	13A, 55B	21A, 144B	27A, 183B	43A, 233B	55A, 233B



ABC Powder Portable



Scan code for Tech specs, Application areas and Product video.

WHEELED EXTINGUISHERS :

Sizes	25 Kg	50 Kg	100 Kg
BS EN-1866 Fire Ratings	A, IVB	A, IVB	A, IVB



ABC Powder Wheeled

Scan code for Tech specs, Application areas and Product video.



CO₂ PORTABLE & WHEELED EXTINGUISHERS

OVERVIEW:

Ceasefire's sturdy and light CO₂ extinguisher is very effective in putting out fires in large spaces. Packed with tremendous power, it reduces the fire's oxygen supply, and brings the temperature down drastically, extinguishing the flames in seconds

FEATURES:

- Fights Class B, C and Electrically started fires.
- Frost-free horn to dispense gas, removes risk of freeze burn.
- State-of-the-art Used/Ready indicator in selected range.

SIZES AVAILABLE:

- **Portable** :- 2 Kg, 5 Kg.
- **Wheeled** :- 20 Kg.



Sizes	2 Kg	5 Kg	20 Kg
BS EN-3 Fire Ratings	34B 55B 89B	34B 70B 89B	—
BS EN-1866 Fire Ratings	—	—	113B



Scan code for Tech specs, Application areas and Product video.

WATER PORTABLE & WHEELED EXTINGUISHERS (JET MODEL)

OVERVIEW:

Water has always been fire's deadliest foe. Ceasefire's Water extinguisher uses proprietary Stored Pressure Technology to deliver a high power throw of water. This ensures it fights fires effectively and enables the firefighter to maintain a safe distance from the flames.

FEATURES:

- Fights Class A fires.
- EPDM / Braided Rubber Hosepipe.
- Easy Snap Safety Pin.
- State-of-the-art Pressure Gauge in portable range.
- Powder Coated cylinder liner.
- Deep Drawn Body in the portable range.
- Extinguishant dispersed via specially designed Jet Nozzle.
- Equipped with Schraeder Valve and Pressure Relief Valve [available only in portable range].



SIZES AVAILABLE:

- **Portable** :- 6 Ltr, 9 Ltr.
- **Wheeled** :- 50 Ltr, 100 Ltr, 135 Ltr.



Sizes	6 Ltr	9 Ltr	50 Ltr	100 Ltr	135 Ltr
BS EN-3 Fire Ratings	13A	21A	—	—	—
BS EN-1866 Fire Ratings	—	—	A	A	A



Water Portable

Water Wheeled

Scan code for Tech specs,
Application areas and
Product video.



Scan code for Tech specs,
Application areas and
Product video.



FOAM PORTABLE & WHEELED EXTINGUISHERS (ASPIRATING MODEL)

OVERVIEW:

Fire needs oxygen to grow. Without it, even the largest fires die out in minutes. Ceasefire's Foam extinguisher exploits this weakness by discharging a mechanical foam that blankets the flames and cuts off the oxygen supply. It's what we like to call simple and effective firefighting.

FEATURES:

- Fights Class A and B fires.
- State-of-the-art Pressure Gauge in portable range.
- Deep Drawn Body in the portable range.
- Stored Pressure technology for more effective firefighting.
- Squeeze Grip mechanism for quick and easy use.
- Epoxy polyester powder coated internal container lining.
- Equipped with Schraeder Valve and Pressure Relief Valve (available only in portable range).



SIZES AVAILABLE:

- **Portable** :- 3 Ltr, 6 Ltr, 9 Ltr.
- **Wheeled** :- 50 Ltr, 100 Ltr, 135 Ltr.

FIGHTS CLASS	CERTIFICATIONS
A B	    

Sizes	3 Ltr	6 Ltr	9 Ltr	50 Ltr	100 Ltr	135 Ltr
BS EN-3 Fire Ratings	8A, 89B	13A, 144B	21A, 233B	—	—	—
BS EN-1866 Fire Ratings	—	—	—	A, IVB	A, IVB	A, IVB



Foam Portable



Scan code for Tech specs, Application areas and Product video.

Foam Wheeled



Scan code for Tech specs, Application areas and Product video.

CLEAN AGENT PORTABLE EXTINGUISHERS

OVERVIEW:

Ceasefire's Clean Agent Portable Extinguishers are one of most powerful extinguishers in our portfolio. It has zero ODP (Ozone Depletion Potential) and is an easy pick for the concerned corporates. While powder-based extinguishers are adept at handling electrically started fires, Clean Agent-based Extinguishers are built to put out such fires and save sensitive electronic equipment too.

These extinguishers adhere to the most stringent international norms on fire safety and many times surpass them too.

FEATURES:

- Available in Fluoroketone (FK) and HFC236FA.
- Fights class A, B, C and Electrically started fires.
- Zero collateral damage and residue-free.
- Magnetic Pressure Gauge.
- Zero Ozone Depletion Potential (ODP).
- Safe Low Pressure Technology that does not displace oxygen in the fire zone.



SIZES AVAILABLE:

- **Portable** :- 2 Kg, 4 Kg, 6 Kg, 9 Kg.



Sizes	2 Kg	4 Kg	6 Kg	9 Kg
BS EN-3 Fire Ratings	21B	21B 34B	34B	55B



Scan code for Tech specs, Application areas and Product video.



WET CHEMICAL PORTABLE EXTINGUISHERS

OVERVIEW:

In commercial kitchens, the liberal use of fire and the presence of combustible substances make it easy for a fire to flare up. Designed to fight kitchen oil and fat fires, Ceasefire's Wet Chemical fire extinguisher uses an environmental friendly foaming agent that blankets the flames, cuts off the supply of oxygen and cools the oil to below the self-ignition point.

FEATURES:

- Fights class A, F and Electrically started fires.
- Bio-degradable extinguishing agent.
- Reduces risk of re-ignition.
- Suitable for use on live electrical equipment upto 1000 V from a distance of 1 meter.
- Epoxy polyester powder coated internal container lining.
- Equipped with Schraeder Valve and Pressure Relief Valve.

SIZES AVAILABLE:

- **Portable :-** 3 Ltr, 6 Ltr, 9 Ltr.



Sizes	3 Ltr	6 Ltr	9 Ltr
BS EN-3 Fire Ratings	8A, 40F	13A, 75F	21A, 75F



Scan code for Tech specs, Application areas and Product video.

LITHIUM ION BATTERY PORTABLE EXTINGUISHERS

OVERVIEW:

Lithium batteries are becoming a more common fire hazard as the number of consumer and industrial products fueled by lithium-ion batteries expands. They are becoming popular because of the power they can create at a given weight and size as compared to conventional lead-type batteries. Because of their high-temperature sensitivity, they are inherently flammable. Due to heat, these battery packs degrade much faster than they would normally.

Lithium-ion battery packs can catch fire and cause extensive damage if they malfunction.

FEATURES:

- Effective on Class A and B fires also.
- Environment friendly.
- No PFAS/PFOS.
- Non-toxic.
- Specialised gel agent.
- 100% biodegradable.

SIZES AVAILABLE:

- **Portable** :- 500g, 1 Ltr, 2 Ltr, 3 Ltr, 6 Ltr, 9 Ltr.



FIGHTS CLASS

A B 

CERTIFICATIONS

CE ₁₁₂₈ UK CA

LITHIUM ION PORTABLE

Sizes	500 g	1 Ltr	2 Ltr	3 Ltr	6 Ltr	9 Ltr
BS EN-3 Fire Ratings	1A, 5B	2A, 8B	5A, 21B	8A, 34B	13A, 113B	21A, 183B
Battery Fire Ratings	50 W/h	175 W/h	350 W/h	600 W/h	900 W/h	1200 W/h



Scan code for Tech specs, Application areas and Product video.



LITHIUM ION BATTERY COMPRESSED AIR FIRE EXTINGUISHERS

OVERVIEW:

A flagship feature of the range are the special 9ltrs and 50 ltrs variants which come in unique back-pack and trolley-mounted designs and are powered by external compressed air cartridges and specialised guns which can easily shift from a jet discharge mode to a Spray mode with a simple turn of the bezel.

These specialised variants in the Ceasefire Lithium-ion range bring in incredible power and versatility adding a huge throw of the extinguishers, that aids in the safety of the fire fighter.

FEATURES:

- Dual phase extinguishing gun with an adjustable nozzle.
- Effective on Class A and B fires also.
- Environment friendly.
- No PFAS/PFOS.
- Non-toxic.
- Specialised gel agent.
- 100% biodegradable.

SIZES AVAILABLE:

- **Portable :-** 9 Ltr, 50 Ltr.

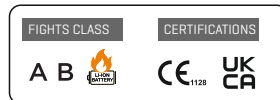

Sizes	9 Ltr	50 Ltr
BS EN-3 Fire Ratings	21A, 183B	A, IIB
Battery Fire Ratings	1500 W/h	3000 W/h



Scan code for Tech specs, Application areas and Product video.

B PLUS SPECIAL APPLICATION (CLASS B) EXTINGUISHERS

OVERVIEW:

Ceasefire's B Plus quadruples the power of a conventional extinguisher! It's the perfect extinguisher for petrol stations and petrochemical plants. The Ceasefire B Plus is ideal for Class B and C fires involving gasoline, alcohol, industrial chemicals, and more. When activated, its unique powder splits into four, covering a large surface area. So when faced with a high risk of class B fires like petrol, diesel, etc. You go for B Plus.

FEATURES:

- Fights Class B, C and Electrically started fires.
- Unique powder splits into four upon activation.
- High power agent throw covers a huge surface area.
- Equipped with Schraeder Valve and Pressure Relief Valve.

SIZES AVAILABLE:

- **Portable :-** 2 Kg, 4 Kg, 6 Kg, 9 Kg.



Sizes	2 Kg	4 Kg	6 Kg	9 Kg
BS EN-3 Fire Ratings	89B	233B	233B	233B



Scan code for Tech specs, Application areas and Product video.



WATERMIST PORTABLE FIRE EXTINGUISHERS

OVERVIEW:

The cleanest extinguishing agent known to man - Water. These extinguishers use stored pressure technology, advanced rotors and specially designed nozzles to generate an ultra fine spray of water called Watermist. Blocking the entry of oxygen in the fire zone and bringing down the temperature to below combustion levels. Enter the Ceasefire watermist fire fighting systems that increase the power of water 400 times over.

FEATURES:

- Fights class A, F and Electrically started fires.
- Green extinguishing technology.
- Low water usage.
- Stainless steel containers.
- Environment friendly.
- Suitable for use on live electrical equipment upto 1000 V from a distance of 1 meter.



SIZES AVAILABLE:

- **Portable** :- 2 Ltr, 3 Ltr, 6 Ltr, 9 Ltr.



Sizes	2 Ltr	3 Ltr	6 Ltr	9 Ltr
BS EN-3 Fire Ratings	5A, 25F	8A, 25F	13A, 75F	21A, 75F



Scan code for Tech specs, Application areas and Product video.

FOAMMIST & GREEN-FOAMMIST PORTABLE EXTINGUISHERS

OVERVIEW:

Ceasefire Foammist extinguisher range, harness the combined power of the revolutionary watermist technology and foam in its range of extinguishers. The foam mist fire fighting system forms a foam blanket on top of the fire, thereby eliminating entry of oxygen and killing the fire instantly.

FEATURES:

- Fights class A, B, F and Electrically started fires.
- Green extinguishing technology.
- Low water usage.
- Highly safe and effective.
- Environment-friendly.
- Suitable for use on live electrical equipment upto 1000 V from a distance of 1 meter.



SIZES AVAILABLE:

- **Foam mist** :- 2 Ltr, 6 Ltr.
- **Green Foam mist** :- 2 Ltr, 6 Ltr.



Sizes	2 Ltr	6 Ltr
Foammist	5A, 55B, 25F	13A, 144B, 40F
Green-Foammist	5A, 34B, 25F	13A, 133B, 40F



Foammist Portable

Green-Foammist Portable

Scan code for Tech specs,
Application areas and
Product video.



Scan code for Tech specs,
Application areas and
Product video.



QUAD (WATERMIST, FOAMMIST & GREEN-FOAMMIST WHEELED EXTINGUISHERS)

OVERVIEW:

Ceasefire Quad brings together the efficiency of a fire extinguisher with the power of a hydrant system. It breaks water down into a fine mist of under 80 microns and covers a large surface area, reducing the temperature to below combustion levels. Meant for areas where fire risk is huge, or where large amounts of combustible materials are stored, the trolley-mounted Quad can be taken anywhere with ease.

FEATURES:

- Fights class A, B, C, F and Electrically started fires.
- Green extinguishing technology.
- Low water usage.
- Highly safe and effective.
- Environment-friendly.
- Suitable for use on live electrical equipment upto 1000V from a distance of 1 meter.



SIZES AVAILABLE:

- **Watermist** :- 25 Ltr, 50 Ltr, 100 Ltr.
- **Foam mist** :- 25 Ltr, 50 Ltr, 100 Ltr.
- **Green-Foammist** :- 25 Ltr, 50 Ltr, 100 Ltr.



Sizes	25 Ltr	50 Ltr	100 Ltr
Watermist	A	A	A
Foammist	A, IVB	A, IVB	A, IVB
Green-Foammist	A, IB	A, IVB	A, IVB



Scan code for Tech specs, Application areas and Product video.

Ceasefire Accessories

Increasing the Agility
& Intelligence Quotient
of Fire Extinguishers



FIRE SUITS

OVERVIEW:

A blazing fire emits massive amounts of heat and smoke, making it dangerous, and at times, impossible to approach. This seriously hampers the ability to extinguish the fire. Which is precisely why, Ceasefire Fire Suits offer the protection required to get close enough to a fire, fight it effectively and avoid injury.

FEATURES:

- High heat resistance; withstands heat at about 1000 C in flash fires without any burning or melting and less than 5% shrinkage.
- Limited inflammability.
- 450N tensile strength, seam tensile strength and residual strength.
- 25N tear strength.
- Marked with strategically located fluorescent 3M reflective tapes.



Scan the QR code to know more about the product

THREE CRITICAL ELEMENTS THAT GIVE CEASEFIRE FIRE SUITS A DEFINITE EDGE:

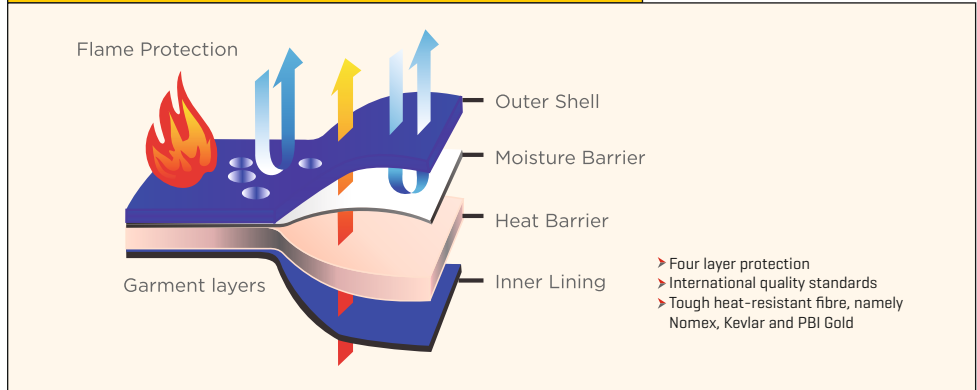

POWER

Entry-level fire suits to tackle small and medium-sized fires.



ALUSTAR

Dual-mirror Kevlar fabric for proximity, bulk flammable liquids and flammable gas firefighting.



ARCSTAR

Designed to guard against the intense, destructive heat of electrical arcs.



GOLDSTAR

High-end protective suits made of PBI Gold material.



METALSTAR

DuPont NOMEX MetalPro Plus, the perfect guard against industrial hazards.

CEASEFIRE INSTALERT

OVERVIEW:

Even though environments are protected with fire extinguishers, what protects the extinguishers from being misused, vandalised or stolen? What you need is a device that can protect the extinguisher 24x7. So that in the case of an emergency, the extinguisher works perfectly, puts out the flames and saves lives.

FEATURES:

- Anti-theft fire alarm.
- Highly visible, compact design that's easily mountable.
- Powerful 98dB warning alarm when activated.
- Self-contained 9V DC alkaline power source.
- Tough polycarbonate housing.



Scan the QR code for additional information about the product.



STROLLEYS

OVERVIEW:

Fires can happen anywhere and at any time. Which makes it important to install extinguishers in relevant places. But, what happens when a fire breaks out and the equipment is not easy to ferry around? Ceasefire presents the perfect accessory to mobilise your fire fighting equipment. Our range of innovative fire extinguisher strolleys are capable of carrying one or two extinguishers. Think of them as life savers on wheels.

FEATURES:

- High quality construction for easy mobility.
- Retractable handles.
- Photo luminescent signs for visibility through smoke and darkness.
- Powder-coated, rustproof bodies.
- Available in Single Type & Double Type.



Scan the QR code for additional information about the product.



FLAT PACK TUBULAR EXTINGUISHER STANDS [CHROME FINISH]

OVERVIEW:

An aesthetically pleasing design that epitomises functionality, these Fire Extinguisher Stands in Chrome finish are an ideal choice for most spaces. The stands come with a CO2 fixing bracket and a J-bracket for easy and steady installation along with a provision to attach a sign clip for extinguisher identification.

FEATURES:

- High quality tubular frame in chrome finish.
- Tubing diameter of 25mm.
- Black plastic base to protect the stand.
- Comes in a box packaging for ease of transit and storage.
- Easy to assemble.
- Available in Single, Double, and Triple extinguisher stand variants.



Scan code for Tech specs, Application areas and Product video.

PROVISION FOR ACCESSORIES

The stands comes with a provision to add a placard and a clip for mounting of signage. For details on the signages available please refer to the Signages section under Accessories.



Single Fire Extinguisher Stand



Size: L-710 x B-320 x H-70 mm

Double Fire Extinguisher Stand



Size: L-715 x B-505 x H-70 mm

Triple Fire Extinguisher Stand



Size: L-715 x B-650 x H-70 mm

SIGNAGES

OVERVIEW:

Did you know that the majority of the fires start in electrical mains, or because of an electrical short circuit? And even those fires that start elsewhere may, eventually result in a failure of electricity, because of damage to the mains and wiring. Which means that in a fire situation, you can be sure that at some point, the entire premises will be plunged into darkness.

Noxious black smoke will fill the air, increasing the risk of asphyxiation for all in the area. A frightening scenario when you consider the fact that asphyxiation and smoke poisoning are the highest causes of casualties in any fire. Darkness and poisonous smoke. A sure recipe for panic and utter chaos.

In such a situation, the single most important need of the hour is to evacuate all those on the premises to the nearest point of safety. As efficiently and quickly as possible. And Ceasefire, quite literally, shows you the way.

Fire action

if you discover a fire

	Operate nearest fire alarm point.
	Call the Fire brigade by telephoning 999
	Leave the building by the nearest exit.
	Report to your assembly point at
	Do not stop to collect personal belongings.
	Do not use lift.

FIRE SAFETY SIGNS

Locator signs, fire extinguisher identification signs and more.

Safe for: Wood, paper and textiles. ✓

Not for: Flammable liquids. ✗

Not for: Flammable metal fires. ✗

Not for: Live electrical equipment. ✗

Water

Safe for: Wood, paper and textiles. ✓

Safe for: Flammable liquids. ✓

Safe for: Gaseous fires. ✓

Safe for: Live electrical equipment. ✓

ABC Powder

Fire extinguisher inside

In case of fire

DO NOT use the lift

Use the stairs

Don't use in case of fire

In case of a fire, the firefighting equipment on the premises needs to be located and activated quickly.

Ceasefire Fire Safety Signs help guide people to the nearest extinguishers, hosepipes, emergency alarms and so on.

ESCAPE ROUTE SIGNS

Exit signs, fire exit signs and more.



The fact is, you never know where you may be when fire strikes and results in pitch darkness. You could be far from your cabin, in an unfamiliar part of the premises.

Ceasefire's Escape Route Signs ensure that from any point on the premises, occupants will have clear directions to the closest safe exit in case of an emergency.

MARKING STRIPS

Exit signs, fire exit signs and more.



Marking strips are critical in areas that need special navigation in the dark, such as around pillars, corners, low-lying or protruding objects, heavy machines etc.

These floor-mounted strips glow brightly, to guide occupants on a safe, obstruction-free path to the nearest exit.

LOW-LEVEL SIGNAGE SYSTEM

Dense, black smoke from fires makes visibility harder than one can imagine. As the smoke rises, it can make even fire escape signs difficult to spot at a distance. This can hamper evacuation and firefighting.

The Low-Level Signage System is a comprehensive solution to this problem.

These durable, high-grade photoluminescent strips run throughout the premises, leading you to fire escapes, fire extinguisher locators, assembly points and evacuation routes. They complement, and can incorporate the entire range of Ceasefire SEE fire safety and escape route signs.

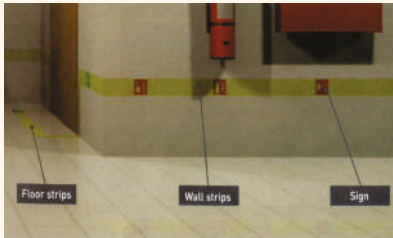

The low-level signage system follows a simple principle: as smoke rises, it becomes easier to see at a lower level. Therefore, installing these strips along the floor, and on walls at a height of 0.4 metres or less, makes them instantly visible. Even if the area is full of smoke.

The Ceasefire design cell helps in This process by surveying the entire location for obstructions, alternative exits and other contingencies, and customising the system for the location. A team of specialised engineers then install the system, without disrupting the normal functioning of the facility. So you don't have downtime or panic. Just a clear path to safety.



EVACUATION PLAN

In densely populated areas such as schools, factories, hotels, cinemas etc.with cubicles and complex layouts, it is extremely important to have an effective evacuation plan. In case of a fire, this plan could literally be the difference between tragedy and hundreds of lives saved.

And as with any life saving device, an evacuation plan is not something that can be bought across the counter and utilized in any

fashion. It requires careful planning and assessment by experts, to maximise both safety and efficiency of evacuation in an emergency.

The Design team at Ceasefire puts together meticulous evacuation plans only after carefully inspecting the premises, taking into consideration all the disparate factors that come into play if a fire breaks out.



Fire Action

1. Operate nearest fire alarm.
2. Leave building by the nearest exit.
3. Report to assembly point.

CODE: CF-001522
Size: 200 X 150 MM

Fire Action

1. Operate nearest fire alarm.
2. Leave building by the nearest exit.
3. Report to assembly point.

CODE: CF-001523
Size: 300 X 250 MM

Fire action
if you discover a fire

- Operate nearest fire alarm point.
- Call the Fire Brigade by telephoning 999
- Leave the building by the nearest exit.
- Report to your assembly point at
- Do not stop to collect personal belongings.
- Do not use lift.

CODE: CF-001524
Size: 200 X 150 MM

Fire action
if you discover a fire

- Operate nearest fire alarm point.
- Call the Fire Brigade by telephoning 999
- Leave the building by the nearest exit.
- Report to your assembly point at
- Do not stop to collect personal belongings.
- Do not use lift.

CODE: CF-001525
Size: 300 X 250 MM

Fire action
if you discover a fire

- Operate nearest fire alarm point.
- Call the Fire Brigade by telephoning 999
- Leave the building by the nearest exit.
- Report to your assembly point at
- Do not stop to collect personal belongings.
- Do not use lift.

CODE: CF-001526
Size: 200 X 150 MM

Fire action
if you discover a fire

- Operate nearest fire alarm point.
- Call the Fire Brigade by telephoning 999
- Leave the building by the nearest exit.
- Report to your assembly point at
- Do not stop to collect personal belongings.
- Do not use lift.

CODE: CF-001527
Size: 300 X 250 MM

Fire action
if you discover a fire

- Operate nearest fire alarm point.
- Fire Brigade will be called automatically.
- Leave the building by the nearest exit.
- Report to your assembly point at
- Do not stop to collect personal belongings.
- Do not use lift.

CODE: CF-001528
Size: 200 X 150 MM

Fire action
if you discover a fire

- Operate nearest fire alarm point.
- Fire Brigade will be called automatically.
- Leave the building by the nearest exit.
- Report to your assembly point at
- Do not stop to collect personal belongings.
- Do not use lift.

CODE: CF-001529
Size: 300 X 250 MM

Fire action
if you discover a fire

- Operate nearest fire alarm point.
- Fire Brigade will be called automatically.
- Leave the building by the nearest exit.
- Report to your assembly point at
- Do not stop to collect personal belongings.
- Do not use lift.

CODE: CF-001530
Size: 200 X 150 MM

Fire action
if you discover a fire

- Operate nearest fire alarm point.
- Fire Brigade will be called automatically.
- Leave the building by the nearest exit.
- Report to your assembly point at
- Do not stop to collect personal belongings.
- Do not use lift.

CODE: CF-001531
Size: 300 X 250 MM

Staff Fire Action Routine

- Operate nearest fire alarm point.
- Call the Fire Brigade.
- Fight the fire, if safe and trained to do so.
- Evacuate the building via the nearest exit.
- Do not stop to collect personal belongings.
- Do not use lift.

CODE: CF-001532
Size: 200 X 150 MM

Staff Fire Action Routine

- Operate nearest fire alarm point.
- Call the Fire Brigade.
- Fight the fire, if safe and trained to do so.
- Evacuate the building via the nearest exit.
- Do not stop to collect personal belongings.
- Do not use lift.

CODE: CF-001533
Size: 300 X 250 MM



Water

- Safe for: Wood, paper and textiles. ✓
- Not for: Flammable liquids. ✗
- Not for: Flammable gases. ✗
- Not for: Live electrical equipment. ✗

CODE: CF-001513
Size: 150 X 105 MM



Foam

- Safe for: Wood, paper and textiles. ✓
- Safe for: Flammable liquids. ✓
- Not for: Flammable gases. ✗
- Not for: Live electrical equipment. ✗

CODE: CF-001514
Size: 150 X 105 MM



Carbon Dioxide

- Not for: Wood, paper and textiles. ✗
- Safe for: Flammable liquids. ✓
- Not for: Flammable gases. ✗
- Safe for: Live electrical equipment. ✓

CODE: CF-001515
Size: 150 X 105 MM



ABC Powder

- Safe for: Wood, paper and textiles. ✓
- Safe for: Flammable liquids. ✓
- Safe for: Flammable gases. ✓
- Safe for: Live electrical equipment. ✓

CODE: CF-001516
Size: 150 X 105 MM



Wet Chemical

- Safe for: Wood, paper and textiles. ✓
- Not for: Flammable liquids. ✗
- Not for: Flammable gases. ✗
- Not for: Live electrical equipment. ✗
- Safe for: Cooking oils and deep fat fryers. ✓

CODE: CF-001517
Size: 150 X 105 MM



Water Mist

- Safe for: Wood, paper and textiles. ✓
- Not for: Flammable liquids. ✗
- Safe for: Live electrical equipment. ✓
- Safe for: Cooking oils and deep fat fryers. ✓

CODE: CF-001518
Size: 150 X 105 MM



Foam Mist

- Safe for: Wood, paper and textiles. ✓
- Safe for: Flammable liquids. ✓
- Safe for: Live electrical equipment. ✓
- Safe for: Cooking oils and deep fat fryers. ✓

CODE: CF-001519
Size: 150 X 105 MM



BC Powder

- Not for: Wood, paper and textiles. ✗
- Safe for: Flammable liquids. ✓
- Safe for: Flammable gases. ✓
- Safe for: Live electrical equipment. ✓

CODE: CF-001520
Size: 150 X 105 MM



Clean Agent

- Not for: Wood, paper and textiles. ✗
- Safe for: Flammable liquids. ✓
- Not for: Flammable gases. ✗
- Safe for: Live electrical equipment. ✓

CODE: CF-001521
Size: 150 X 105 MM





Giving Extinguishers The Place They Deserve



FLAT PACK TROLLEYS

OVERVIEW:

Ceasefire Trolleys exemplify functionality by adding maneuverability to the stocking point of the fire safety equipment. It enables easy treading of the equipment to the fire source aiding efficient fire fighting. The trolley has a provision to accommodate upto 2 fire buckets.

FEATURES:

- Mild steel tubular body.
- Epoxy polyester powder paint finish in red.
- Nylon wheels with rubber tread for easy and quick deployment.
- Comes in a box packaging for ease of transit and storage.
- Available in Single, Double, and Triple extinguisher trolley variants.



Scan the QR code for additional information about the product.

PROVISION FOR ACCESSORIES

The trolleys are equipped with provisions to install fire bucket. The universal mounting bracket makes it easy to use for all extinguisher types, makes, and designs.



Trolleys for Extinguisher and a Fire Bucket

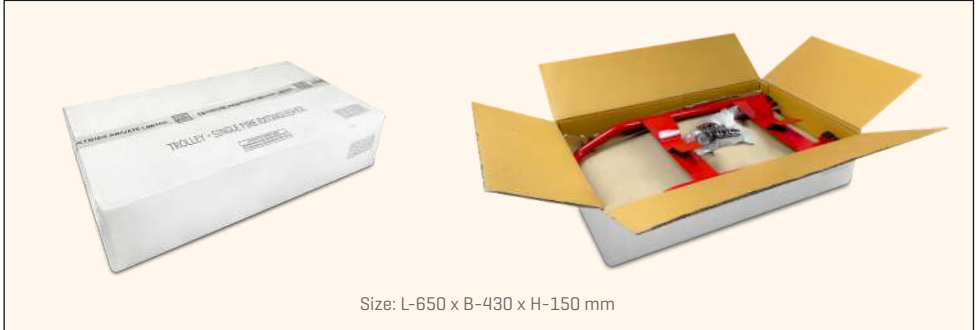

Size: L-650 x B-430 x H-150 mm

Trolleys for Double Extinguisher and a Fire Bucket

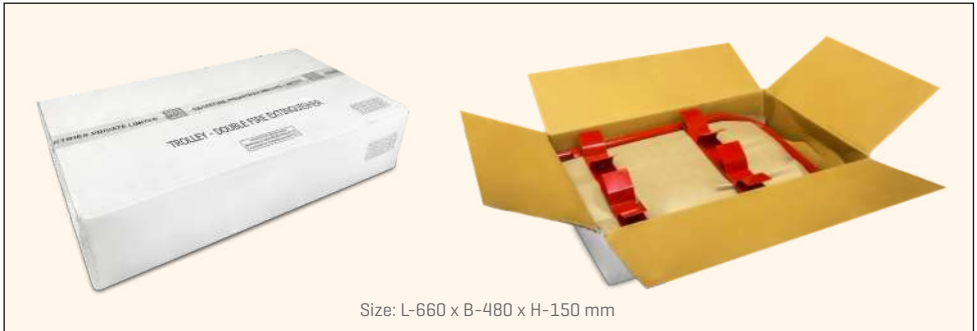

Size: L-660 x B-480 x H-150 mm

Trolleys for Triple Extinguisher and a Two Fire Buckets



Size: L-720 x B-675 x H-150 mm

FLAT PACK FIRE EXTINGUISHER STAND

OVERVIEW:

Ceasefire's Contractor Stand is a multi-utility fire safety station that stores fire extinguishers, safety signs, evacuation plan, medical kit and an evacuator as per the individual needs of the premises.

This being a comprehensive unit carries ample ammunition to provide first line of defence against fire. The stand comes with wheels that make it maneuverable, easy to cart around and can be taken to the point of fire with much ease.

FEATURES:

- Stand body is built using a round tube made of mild steel.
- Outer body is epoxy polyester powder coated in red .
- The base has plastic wheels with nylon tyres that aids easy mobility.
- Comes in a box packaging for ease of transit and storage.
- The Ceasefire Contractor Stand can accommodate 3 extinguishers, safety signs, optional evacuator, and a fire plan.



Scan the QR code for additional information about the product.

SUPPRESSION SYSTEMS

IN THIS SECTION

ENGINEERED SYSTEMS



In-Panel Tube Based
Suppression System



Total Flooding System



Inert Gas Suppression
System



Atom X - Retrofittable
Suppression System

STANDALONE SYSTEMS



Automatic Extinguishers
[Wall Mounted]



Automatic Extinguishers
[Ceiling Mounted]



Ceasefire Mini



Server Quick Response
System



Launcher [Extinguisher +
Modular Systems]



A FULL-SPECTRUM OF SUPPRESSION SYSTEMS

Ceasefire today offers an extensive range of fire suppression systems to suit the needs of every kind of premises. The range comprises of solutions ranging from Room Suppression Systems like Inert Gas & CO2 based Suppression System and Retrofittable

Ceiling Mounted Suppression System, to Cabinet Fire Systems like the In-panel Tube based Fire Suppression Systems and Ceasefire Mini - Micro Environment Fire Suppression to fire-proof small spaces that are vulnerable to catching fire.



Widest Range of Fluoroketone Based [FK] Based Suppression



Ceasefire In-panel Tube Based Suppression



Ceasefire Mini



Ceasefire Atom X



Automatic Extinguishers (Wall mount & Ceiling mount)

CERTIFICATIONS



Tested by BSI



LPS 1666
Cert/LPCB Ref. 1329K



LPS 1230
Cert/LPCB Ref. 1329e



VDS Approved

Ceasefire's In-Panel Tube-Based Fire Suppression System

Ceasefire's Clean Agent & Inert Gas Based Fire Suppression System

Ceasefire In-Panel Tube Based Suppression System (CQRS)

Fights Fire That You Can't Even See



Direct Systems



In-Direct Systems



IN-PANEL TUBE BASED SUPPRESSION SYSTEM (CQRS)

OVERVIEW:

How do you detect a fire you cannot even see? Even if detected, how do you effectively fight it in an area that is difficult to access? Ceasefire's In-Panel Tube-based Fire Suppression System (CQRS) is an advanced fire fighting solution which combines ground-breaking technology with functional simplicity to keep what's precious, safe.

FEATURES:

- Fights Class A, B, C and Electrically started fires.
- Self-actuated.
- Environment-friendly.
- Available in two variants: High Pressure (CO₂ Based) & Low Pressure (Powder, Foam and Clean Agent Based) systems.
- Superior extinguishing agents - Fluoroketone (FK), MAP 90 Powder, Foam, HFC227ea, HFC236fa & CO₂.
- No clean-up required after discharge.
- 24-hour protection.



DIRECT VARIANT :

Agents	Sizes
Fluoroketone (Low Pressure)	1 kg, 2 kg, 3 kg, 4 kg, 6 kg & 9 kg
MAP 90 Powder (Low Pressure)	1 kg, 2 kg & 4 kg
FFF (Low Pressure)	1 Ltr., 3 Ltr. & 6 Ltr.
HFC227ea (Low Pressure)	2 kg, 4 kg, 6 kg & 9 kg
HFC236fa (Low Pressure)	2 kg, 4 kg, 6 kg & 9 kg
CO ₂ (High Pressure)	2 kg & 5 kg

IN-DIRECT VARIANT :

Agents	Sizes
Fluoroketone (Low Pressure)	2 kg, 4 kg, 6 kg & 9 kg
MAP 90 Powder (Low Pressure)	2 kg, 4 kg, 6 kg & 9 kg
FFF (Low Pressure)	2 Ltr., 3 Ltr., 6 Ltr. & 9 Ltr.
HFC227ea (Low Pressure)	2 kg, 4 kg, 6 kg & 9 kg
HFC236fa (Low Pressure)	2 kg, 4 kg, 6 kg & 9 kg
CO ₂ (High Pressure)	2 kg, 5 kg & 20 kg

The Complete System:

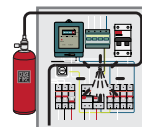
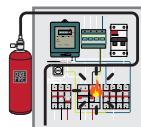
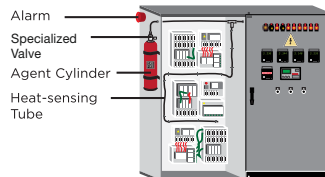

The heat-sensitive polymer tube is connected to an extinguishing agent container via a pressure release valve. When a fire breaks out, it results in a drastic increase in temperature. When it reaches 180° - 200°C, the heat-sensitive tube bursts and activates the valve which in turn

releases the extinguishing agent through the direct or indirect line. The extinguishing agent is sprayed out of the container, flooding the microenvironment and instantly extinguishing the flame.

Types of Systems:

DIRECT SYSTEM

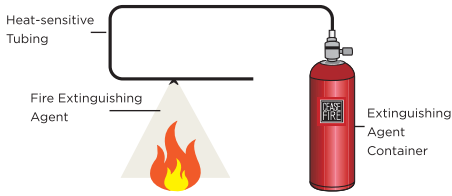

Here, the heat-sensitive tubing acts as an extinguishing agent delivery system. The tube bursts at the point where the fire is detected, forms a miniature nozzle and sprays the extinguishing agent. Ideal for places where fires can break out in localised areas. This is available in low-pressure and high-pressure systems.

INDIRECT SYSTEM

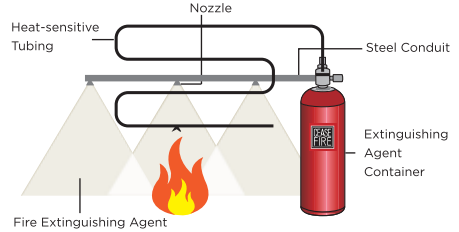

In the Indirect system, the heat-sensitive tubing only acts as a detection device. The extinguishing agent is delivered through a steel conduit and sprayed across the entire area through strategically placed nozzles. Ideal for areas where there is a chance of fires igniting at multiple points. This is available in low-pressure and high-pressure systems.



Scan the QR code for additional information about the product.

CLEAN AGENT BASED TOTAL FLOODING SYSTEM

OVERVIEW:

Areas such as offices, server rooms and data centres where heavy-duty electronics, computers, etc., are stored are prone to fire. Unfortunately, most of the time, while putting out the fire, suppression systems end up damaging the very things they're meant to protect.

The Clean Agent Based Flooding System is the fastest fire protection available. The detectors sense a rise in temperature above normal, particles of smoke, or a change in air quality, and alert the Control Panel. This, in turn, activates the system and triggers the clean agent gas. A hooter goes off, warning personnel to clear the area while the agent is dispersed.



FEATURES:

- Fights Class A, B, C, F and fires involving electrically charged devices.
- Electronics and environment-friendly.
- Superior extinguishing agent - HFC-227ea & Fluoroketone (FK).
- No clean-up required after discharge.
- Can be triggered manually or automatically.
- 24-hour protection.



LPS 1230
Cert/LPCB Ref. 1329e

THE COMPLETE SYSTEM:

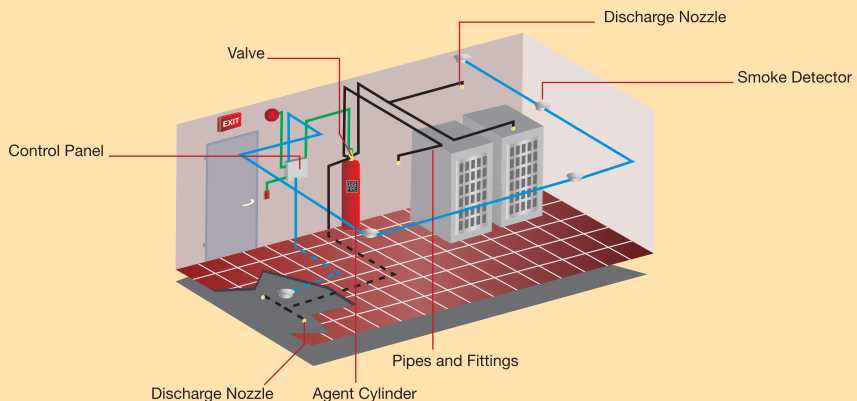

COMPONENTS:

The Clean Agent based Flooding System is designed to conform to IES 15519, the National Fire Protection Association (NFPA) 2001 and ISO/PF 20885 standards.

The system comprises various components that come together to create an unbeatable suppression system.



Agent Tank



Valves and Actuation Line



Nozzles



Pipes and Fittings



Detection Devices



Control Panel



Scan the QR code for additional information about the product.

INERT GAS SUPPRESSION SYSTEM

OVERVIEW:

Ceasefire Inert Gas System uses inert gas or natural gases to extinguish fire. Often used as a blend of gases, these gaseous mixtures leave no residue behind and are designed to protect enclosures where there is a need for quick reaction to extinguishing a fire.

Once activated, the system dumps inert gases in the fire zone, bringing down the oxygen concentration in the fire zone below the fire threshold point. While the oxygen level is lowered, the system does not eliminate oxygen from the space altogether, leaving enough oxygen to support life but not fire!

FEATURES:

- Fights Class A, B, C fires and Electrically started fires.
- Inert gas is among the most environment friendly gases.
- Safe on electronic equipments.
- Self Actuating.
- High-value Risk Protection.
- Speedy Deployment and Minimal Downtime.
- Multiple Triggers.
- 24-hour protection.



Approved by



What gases are used?

CF1: CO₂ [100%] | CF100: Nitrogen [100%]

CF541: A blend of Nitrogen[50%] + Argon[40%] + CO₂[10%]

CF01: Nitrogen [100%] | CF55: A mix of Argon[50%] + Nitrogen[50%]

Components:



Agent Tank



Valves and Actuators



Discharge Nozzles



Pressure gauge



Extinguishing Panel

Scan code for Tech specs, Application areas and Product video.





Atom X

Engineered Retrofittable
Fire Suppression Systems



ATOM X - RETROFITTABLE FIRE SUPPRESSION SYSTEM

OVERVIEW:

Understanding the evolving demands of unique infrastructures and businesses, Ceasefire presents the next generation specialized fire suppression technology. Ceasefire Atom X doesn't demand any structural change neither consumes the floor space nor leads to down time, as this innovative system is mounted on the ceiling of the premises. Designed with smart and sensitive features, it minimizes the possibility of false activation and safeguards the premises. The system is an automated smart network of ceiling mounted agent containers, an array of detection devices and a control panel.

FEATURES:

- Electronics and Environment-friendly.
- Dual detection & activation technology.
- Available in Clean Agent [FK & HFC227ea] & Powder.
- Self Actuating.
- Flexible Design.
- 24-hour protection

SIZES AVAILABLE:

- **ABC Powder / Clean Agent** :- 2 Kg, 5 Kg, 10 Kg, 15 Kg.



bsi.
Tested



Scan code for Tech specs, Application areas and Product video.





Automatic Extinguishers

24X7 Automated Fire Protection

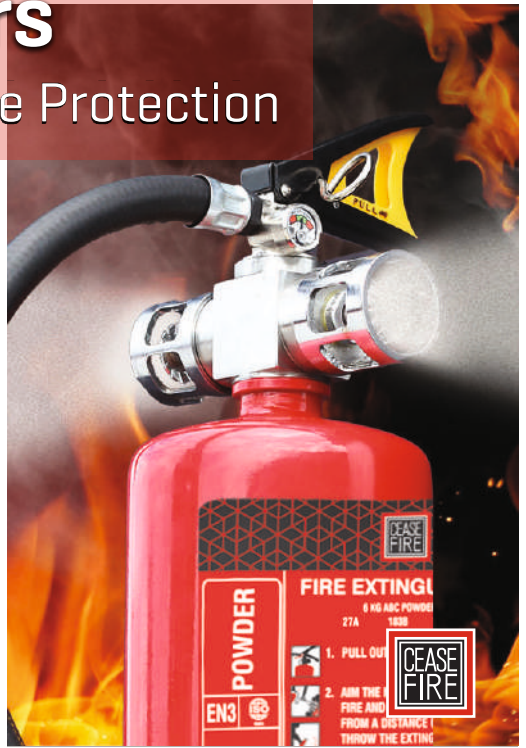

CEASE FIRE
FIRE EXTINGUISHING POWDER
6 KG ABC POWDER
27A 1838
1. PULL OUT
2. AIM THE FIRE AND FROM A DISTANCE THROW THE EXTING

AUTOMATIC EXTINGUISHERS (WALL MOUNTED)

OVERVIEW:

Ceasefire's Wall Mounted Automatic Fire Extinguisher addresses two simple problems; first of fire safety and second of space crunch. Being an automatic extinguisher it is ideal for spaces like boats and engine compartments that are not just prone to fire but also have limited space, where installing an extinguisher can be a challenge.

FEATURES:

- Comes in option of Fluoroketone and Powder.
- Clean agent Fluoroketone based extinguishers do not fall under the ambit of F-gas regulations.
- Works on all classes of fire.
- Automatic detection and suppression.
- Comes with a secure mounting bracket for direct installation on the wall.
- Optional flexible mounting bracket that enables optimal positioning of the extinguisher in the risk zone.

SIZES AVAILABLE:

- **ABC Powder** :- 1 Kg, 2 Kg, 4 Kg, 6 Kg, 9 Kg.
- Fluoroketone [FK]** :- 1 Kg, 1.5 Kg, 2 Kg, 2.5 Kg, 4 Kg, 6 Kg, 9 Kg.



FIGHTS CLASS

CERTIFICATIONS

A B C ⚡

CE₁₁₂₈

TELESCOPING WALL MOUNTING BRACKET

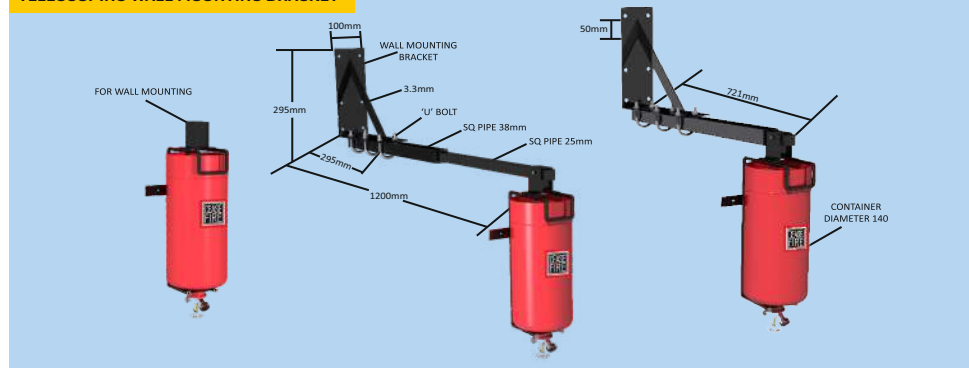

Fluoroketone Extinguishers [FK-5-1-12]

ABC Powder Extinguishers

Scan code for Tech specs,
Application areas and
Product video.



Scan code for Tech specs,
Application areas and
Product video.



AUTOMATIC EXTINGUISHERS [CEILING MOUNTED]

OVERVIEW:

There are areas in a workplace that contain highly flammable materials with little or no human traffic. Here, the chances of fire going undetected are high. Ceasefire's Ceiling mounted extinguisher detects the rising temperature of the area and activates automatically, even when there's no one around, ensuring that the fire is brought under control early and efficiently.

FEATURES:

- Fights class A, B, C and Electrically started fires.
- Automatic discharge mechanism.
- Rigid ceiling mount.
- Comes in option of Clean Agent and Powder.
- Green Technology.

SIZES AVAILABLE:

- **ABC Powder** :- 5 Kg, 10 Kg.
- **Clean Agent** :- 1 Kg, 1.5 Kg, 2 Kg, 4 Kg, 5 Kg, 6 Kg, 9 Kg, 10 Kg, 15 Kg.



bsi.

Tested

FIGHTS CLASS

CERTIFICATIONS

A B C ⚡ CE₁₁₂₈

Smart. Intelligent.
Automated Fire Protection.



Clean Agent Extinguishers



Scan code for Tech specs,
Application areas and
Product video.

ABC Powder Extinguishers



Scan code for Tech specs,
Application areas and
Product video.

CEASEFIRE MINI

OVERVIEW:

The Mini is Ceasefire's state-of-the-art micro-environment suppression system. Palm-sized, it sits snugly inside small enclosed spaces that are vulnerable to fire. When the temperature of the micro-environment exceeds a preset limit, the Mini swings into action and extinguishes the fire. Servers, fuse boxes; the Mini fits anywhere, and protects everywhere.

FEATURES:

- Fights all classes of fire.
- Self-activated and easy to install.
- No power supply required.
- Heat-sensitive glass bulb acts as a heat sensor and actuator.
- Mini is based on an environment friendly clean agents.

SIZES :

- **Adaptive / Intuitive** :- 100 gm, 200 gm, 300 gm, 400 gm, 500 gm.

TYPES OF MINI:

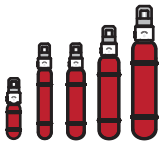

Intuitive System

The Mini Intuitive System is a direct suppression system, which protects the micro-environment from enclosed area inside. Place it inside, or attach it to the inner wall of the micro-environment, and the Mini is ready to protect.

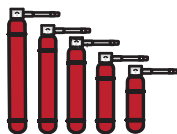
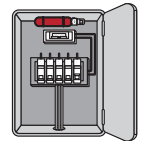

Adaptive System

The Mini Adaptive System is an indirect suppression system designed for those micro-environments which are too small to even accommodate a Mini, let alone other firefighting systems. In this case, the Mini container is installed on the outside, with its heat-sensitive glass bulb inside the micro-environment.

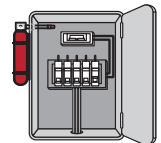

bsi.

Tested



Mini - Intuitive

Scan code for Tech specs, Application areas and Product video.



Mini - Adaptive

Scan code for Tech specs, Application areas and Product video.



LAUNCHER (EXTINGUISHER + MODULAR SUPPRESSION SYSTEM)

OVERVIEW:

This one-of-a-kind extinguisher can be used to fight a fire manually, on auto-pilot when it senses a rise in temperature, or be thrown into the flames. This makes it a revolutionary extinguisher that ensures no fire ever goes undetected or unaddressed. Its biggest advantage is that it eliminates the need for a firefighter to go anywhere near the fire. A huge benefit, especially in case of a large blaze.

FEATURES:

- Fights class A, B, C and Electrically started fires.
- Unique Discharge Mechanism.
- Self-Actuation.
- Quick and effective.
- Two Heat Sensors.
- Extinguisher + Modular Suppression System.

SIZES AVAILABLE:

- **Portable** :- 4 Kg, 6 Kg, 9 Kg.



bsi.
Tested

FIGHTS CLASS

CERTIFICATIONS

A B C ⚡ CE 1128

Sizes	4 Kg	6 Kg	9 Kg
IS 15683 Fire Ratings	4A, 144B	6A, 183B	6A, 233B
BS EN-3 Fire Ratings	21A, 144B	27A, 183B	43A, 233B

Extinguisher + Suppression
Power Packed into One



Scan code for Tech specs, Application areas and Product video.

SERVER QUICK RESPONSE SYSTEM (SQRS)

OVERVIEW:

A blaze in a server room or a data centre could lead to loss of vital information, reputation, and significant expenses in replacing damaged servers, downtime, and sometimes, a full shutdown.

SQRS is powered by HFC227ea - the cleanest extinguishing agent known to man. This fully automated, independent suppression system is perfect for an individual server. It is designed to slot into your existing server racks and quell a fire within seconds of detection.

FEATURES:

- Fights Class A, B, C, & Electrically Started Fires.
- Electronics and environment-friendly.
- Uses superior extinguishing agent - HFC227ea.
- Residue-free, therefore no collateral damage.
- 24-hour protection.
- High-value risk protection.
- Self-activating with multiple triggers.



The Complete System:

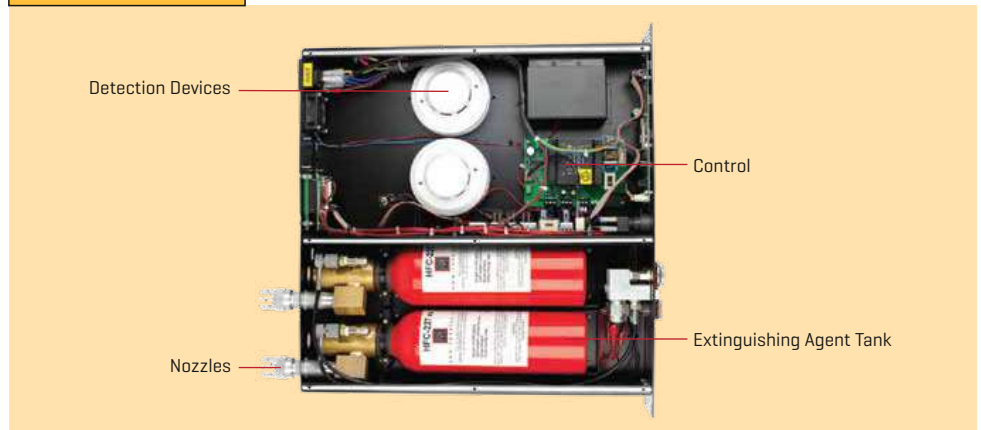

Scan code for Tech specs, Application areas and Product video.



LANCEPRO

OVERVIEW:

Often, when a fire breaks out in any large premises, the first line of responders are the ones at maximum risk. Firefighters need a firefighting system on their side. One that fights its way into sealed off spaces, battles the flames, controls collateral damage and keeps the firefighter at a safe distance.

The Ceasefire Lancepro is powered by Watermist technology. The firefighter makes an opening in the wall with the system kit's rotary hammer, inserts the Lancepro gun and uses the power of Watermist to extinguish the fire.

FEATURES:

- Fights Class A, B, C, F and Electrically started fires.
- Ensures safety of the firefighter with remote access.
- Watermist ensures no collateral damage.
- Two drill bits for use on metal or concrete surfaces.
- Environment-friendly.
- Ideal for rapid reaction.



The Complete System:

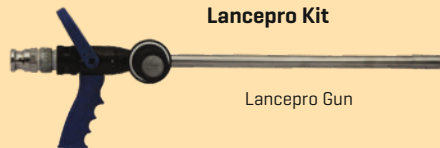
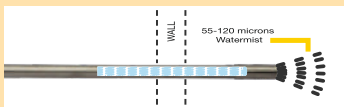

Lancepro Kit

Lancepro Gun



Hammer Drill Machine



Scan the QR code for additional information about the product.

MORPH

OVERVIEW:

Designed to help firefighters take on the largest fires, the Morph is a range of advanced nozzle guns that convert water from fire trucks and hydrants into Watermist, thus increasing its firefighting power manifold.

The Morph Range:

The Converter

This nozzle is ideal for grass fires and bush fires as it dispenses Watermist with a wide throw.

The Transformer

This nozzle is ideal for use by firefighters on light, fast response fire trucks to extinguish Class A, B, C and F fires, as well as Electrically started fires. It can also be used on storage tanks to convert them into Watermist hydrant systems.

The Morpheus

This nozzle is the real deal. It expels Watermist with the most pressure, the most throw and the most reach. It is designed to extinguish Class A, B, C, F as well as Electrically started fires.

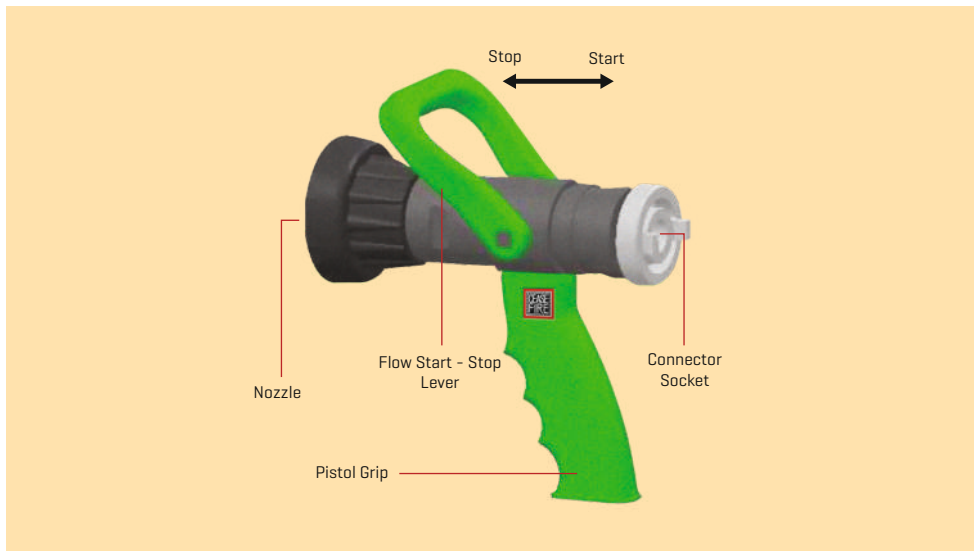

Scan code for Tech specs, Application areas and Product video.



Self Contained Watermist Based **Hydrant Systems**



CF 2000 - HYDRANT SYSTEM

OVERVIEW:

Powered by the revolutionary Watermist technology, CF 2000 increases the firefighting and cooling properties of water, manifold.

It's highly dependable and a standalone firefighter. It has a clear advantage of longevity over other hydrants which might run dry and extinguishers which may exhaust before putting out all the flames.

The CF 2000 practically guarantees an unlimited water supply. It can easily be connected to an existing water pipe/hydrant and pressure line – effectively making hundreds of liters of water & air readily available for fighting the flames. It also features an AFFF Foam additive option for increased extinguishing power.

FEATURES:

- Fights all classes of fires.
- Safe for humans & environment.
- Causes minimal collateral damage.
- Effective use of water.
- Thermal shockproof.
- Powered by Watermist and Foam.



Scan code for Tech specs, Application areas and Product video.



CF 3000 - HYDRANT SYSTEM

OVERVIEW:

When a fire breaks out, external factors such as traffic and construction could prevent fire tenders from making it in time. To beat a fire, you need two important things on your side: quick response time and powerful firefighting equipment that's easily accessible and on the premises.

Ceasefire's CF 3000 is suitable for places with no ready supply of compressed air and water. It features an inbuilt pressure container, water storage and a foam supply unit. Pull out the long hose, activate the device and instantly be armed with CF 3000's immense fire fighting power.

FEATURES:

- Fights all classes of fires.
- Standalone firefighting device.
- Thermal shock proof.
- Powered by Watermist and Foam.
- No power supply required.
- Effective use of water.



Scan the QR code for additional information about the product.

KITCHEN SUPPRESSION SYSTEMS

IN THIS SECTION

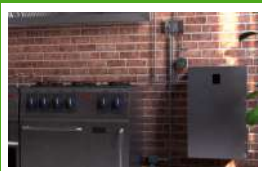

ULtraX Kitchen Fire
Suppression System



Commercial Kitchen
Suppression Systems



Residential Kitchen
Suppression Systems



A FULL-SPECTRUM OF KITCHEN SYSTEMS

Ceasefire today offers an integrated range of kitchen fire suppression systems and fire extinguishers to suit the needs of every kind of a kitchen, be it a commercial

or residential. The range includes Watermist & Wet Chemical Engineered Systems & a host of hand-held extinguishers.



Certified by the world's best agencies

Ceasefire's Commercial kitchen systems are fully certified by LPCB to LPS 1223 standard and the Residential systems are tested by BSI for performance & safety.



Ceasefire's ULtraX Kitchen Fire Suppression Range, Including Wet Chemical Based Systems



LPS 1223
Cert/LPCB Ref. 1329a

Ceasefire's Kitchen Fire Suppression Range, Including Both Watermist & Wet Chemical Based Systems



Tested by BSI

Ceasefire Residential Kitchen Fire Suppression System

WHAT MAKES CEASEFIRE KITCHEN SYSTEMS THE BEST IN THE WORLD?

Customized Design For Every Kitchen

Ceasefire's Kitchen Fire Suppression Systems are designed following comprehensive structured design norms. The systems are configured specifically for a given kitchen site, and the installation details are laid out. These comply with the highest international standards.

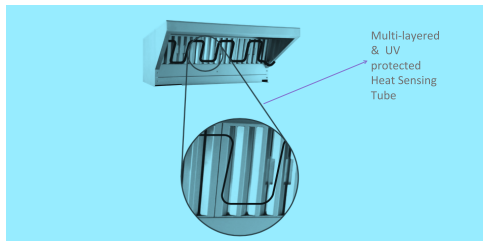
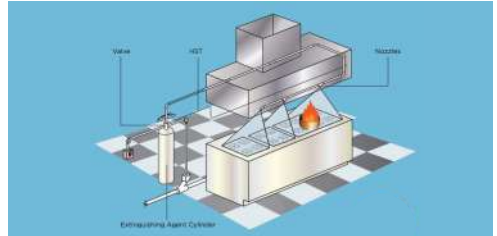

Highly Advanced Heat Sensing Tube Based Fire Detection

The most prominent feature of the Ceasefire kitchen fire suppression systems is a specially designed, high grade, multilayered, pneumatic polymer tube that runs unobtrusively through out the area at risk. This tube offers robust detection with distinct puncture characteristics to form a perfect discharge port for the extinguishing agent.

Next Generation Valve Technology

The System's valves are heavy duty, made of high-grade brass/stainless steel and with an integrated ball valve. This feature ensures against no leakages whatsoever.



Nozzles That Leave No Blind Spots

At Ceasefire, our specially engineered nozzles ensure enhanced throw and their strategic positioning rules out any possibility of a blind spot in the kitchen.

Intelligent Response Panel

The Ceasefire Kitchen Fire Suppression Systems come with an option of a state-of-the-art Response Panel that is capable of monitoring upto four cylinder systems. The Response Panel enables the users to monitor the health and functional readiness of the system with mere observation of indicators on the LCD screen. It also allows the users to integrate the system with other third party devices and systems present in the premises.



ULtraX KITCHEN FIRE SUPPRESSION SYSTEM [WET CHEMICAL BASED]

OVERVIEW:

Ceasefire's UL Listed Commercial Kitchen Suppression Systems offer a distinctive advantage by incorporating both Electrically Triggered or Mechanical Fusible Links based protection. This innovative system is tailored to effectively mitigate the unique fire hazards found in commercial kitchens. When a fire occurs and the temperature reaches a predetermined level, the detection module promptly activates the system. Activation through either of these detection methods results in the agent being discharged through a dedicated discharge line via specialised nozzles leaving no blind spots. The system is designed to give full protection against fire under the hood, plenum, and duct area.



FEATURES:

- Choice of 2 Detection modules: Electrical and Mechanical.
- Highly potent, Reach compliant and Eco-friendly Agent.
- Only two Nozzle Design for all system configurations and application.
- Stored Pressure Technology.
- Saves Floor Space.
- Quick Installation.
- Integrated Gas Shut-Off Valve.
- Electrical cut-off valve.
- Stainless Steel Agent Containers.
- UL Listed system which adheres to the NFPA 96/17A guidelines.

SYSTEM VARIANTS:

Cylinder Size	Agent Capacity	Nozzles
14 ltr	9 ltr	3
18 ltr	12 ltr	4
22 ltr	16.5 ltr	5-7
27 ltr	20 ltr	6-10
32 ltr	24 ltr	8-12
44 ltr	30 ltr	10-14
64 ltr	45 ltr	15-18



Scan the QR code for additional information about the product.

COMMERCIAL KITCHEN SUPPRESSION SYSTEMS - ENVIRO (WATERMIST BASED)

OVERVIEW:

Ceasefire Watermist Kitchen Suppression System comes with an advanced heat detection mechanism. Its Pneumatic Heat Sensing Tube runs through the length of the hood, covering all vulnerable areas. In the event of a fire, this tube bursts at a set temperature point. This bursting of the tube allows the pressurised nitrogen to escape and the pressure to drop in the tube.

This fall of pressure activates the agent container valves, allowing the rotors placed inside the containers to mix air and water in pre-set proportions. The agent is then pushed through the discharge line and expelled from the strategically placed nozzles in the form of watermist, leaving no blind spots.

FEATURES:

- Works on Class A, B and F (cooking oil) fires.
- Automatic detection and actuation.
- Easy and convenient installation.
- An eco-friendly alternative to conventional extinguishing systems.
- Protects kitchen hood lengths upto 10 meters in single type nozzle.
- Supported by trained Design & Support cell.



LPS 1223
Cert/LPCB Ref. 1329a

Components of the System:

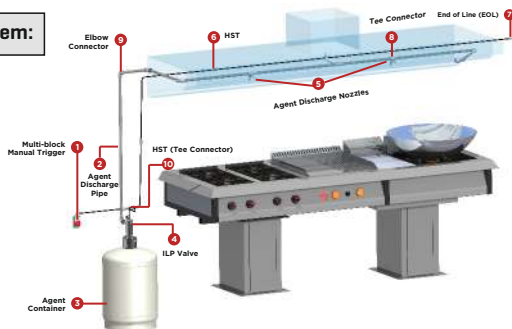

Nozzles: Specially designed nozzles that use minimum water and give maximum extinguishing power.

Sizes available: 27 ltr & 56 ltr.

Scan code for Tech specs, Application areas and Product video.



COMMERCIAL KITCHEN SUPPRESSION SYSTEMS - ULTRA [WET CHEMICAL BASED]

OVERVIEW:

Hazardous oil and grease fires in kitchens take place when oil overheats from 350°C - 380°C. They are further enhanced by the accumulation of oil in the filter and the exhaust ducts of the kitchen hood. Kitchen fires are also caused by user error or malfunctioning equipment in electrical deep fat fryers.

The Ceasefire Wet Chemical Kitchen Suppression Systems are a perfect answer to such kitchen fires. The system, equipped with the advanced detection mechanism in the form of the heat sensing tube, is automatic and is capable of detecting fire and suppressing it even when there is no one around. The uniform detection by the heat sensing tube allows the users to freely move the hot and cold area under the kitchen hood at will.

FEATURES:

- Works on Class A, B and F (cooking oil) fires.
- Automatic detection and actuation.
- Protects kitchen hood lengths upto 15 meters in single type nozzle.
- Easy and convenient installation.
- Supported by trained Design & Support cell.



LPS 1223
Cert/LPCB Ref. 1329a

Components of the System:

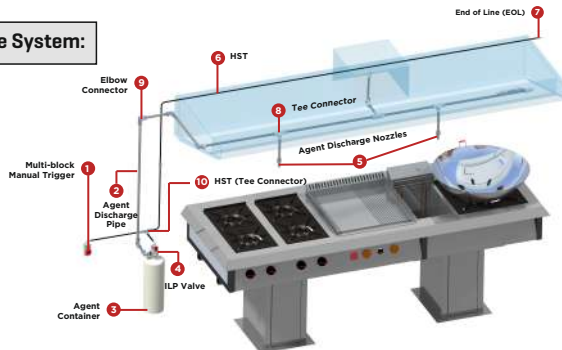

Nozzles: Specially designed nozzles that use minimum water and give maximum extinguishing power.

Sizes available: 11.5 ltr, 18 ltr, 27 ltr & 44 ltr.



Scan the QR code for additional information about the product.

RESIDENTIAL KITCHEN SUPPRESSION SYSTEMS - ENVIRO (WATERMIST BASED)

OVERVIEW:

Ceasefire residential kitchen firefighting range is a modern system that operates automatically in the event of fire, making kitchen as safe as they can be.

Based on the clean watermist technology, the system does not cause any collateral damage and is safe for the kitchen equipment.

FEATURES:

- Works on Class A, B and F [cooking oil] fires.
- Automatic detection and actuation.
- Camouflages with interiors of the kitchen.
- No collateral damage and minimal downtime.
- An eco-friendly alternative to conventional extinguishing systems.
- Easy and convenient installation that does not interfere with the kitchen hood or the decor.



bsi.
Tested

Variants Available:

[1] 3 Litre, 2 Nozzles Variant
[ideally suited for 600 mm
kitchen hoods]

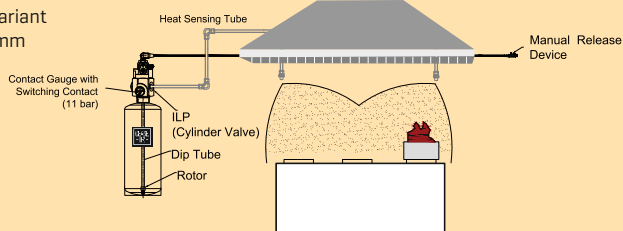

[2] 4.5 Litre, 3 Nozzles Variant
[ideally suited for 900 mm
kitchen hoods]

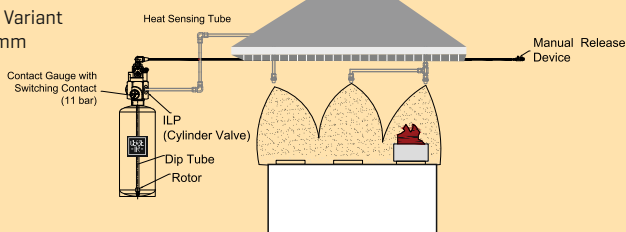

Scan code for Tech specs, Application areas and Product video.



RESIDENTIAL KITCHEN SUPPRESSION SYSTEMS - ULTRA [WET CHEMICAL BASED]

OVERVIEW:

Ceasefire Wet chemical based residential kitchen suppression systems are fully automatic systems that detect fire with the advanced heat sensing tube. Wet chemical being a powerful extinguishing agent against cooking oil fires has a blanketing effect on the flames which cools the super heated oil to below its self-ignition point bringing the fire in control.

The system's unobtrusive design ensures that installing the system does not interfere with the kitchen hood or the decor.

FEATURES:

- Works on Class A, B and F (cooking oil) fires
- Automatic detection and actuation.
- No collateral damage and zero downtime
- An eco-friendly alternative to conventional extinguishing systems.
- Easy and convenient installation that does not interfere with the kitchen hood or the decor.



bsi.
Tested

Variants Available:

[1] 1 Litre, 1 Nozzle Variant

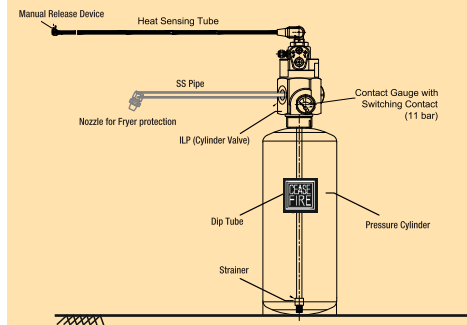

[2] 1 Litre, 2 Nozzles Variant

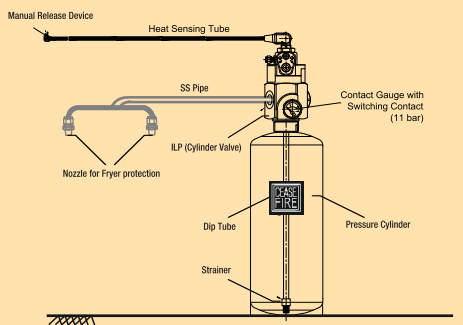

Scan the QR code for additional information about the product.

WATERMIST SUPPRESSION SYSTEMS

IN THIS SECTION



Generator Auto-Quell
System



Transformer Auto-Quell
System



Swift

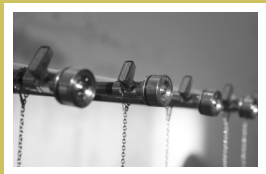

Indoor Auto-quell
System



WIDEST RANGE OF WATERMIST BASED SUPPRESSION SYSTEMS

Ceasefire offers a full-spectrum range of Watermist based suppression systems to suit the needs of every kind of premises and applications. These include

highly advanced Indoor Auto-Quell Systems, Specialized Systems for Generators, Transformers and Kitchen protection.

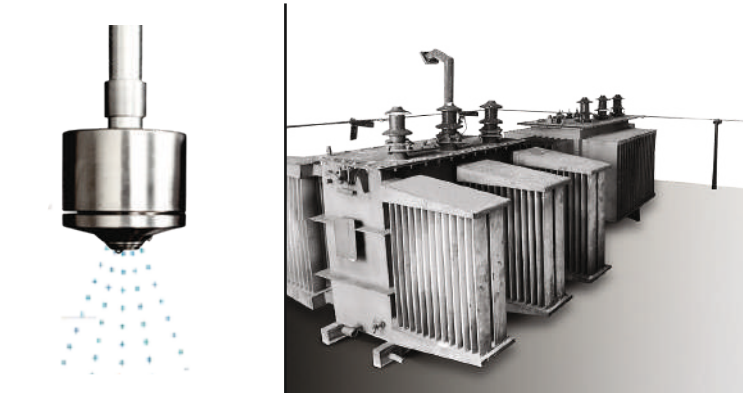

WATERMIST – THE PARADIGM TECHNOLOGY

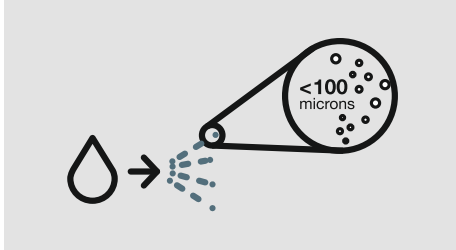

This pioneering technology breaks water down into a fine mist of less than 100 microns.



This mist is then thrown at the fire with an optimal kinetic force, covering a large surface area.

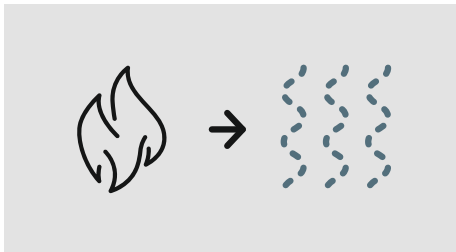

As soon as the mist comes in contact with the fire, it instantly turns into steam, increasing its volume 1600 times over.

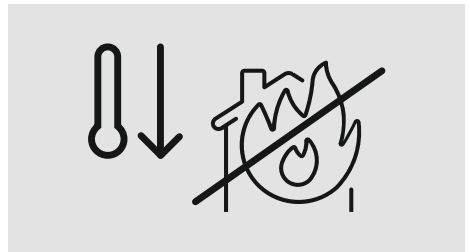

The steam envelops the flames, cutting off the oxygen supply and reducing the temperature to below combustion level. This ensures that even the largest fire succumbs to Watermist technology in seconds.

Evaporation Surface Area & Shielding Surface Area

Various parameters like the force with which water is discharged, the size of water droplet and the nozzle coverage area, make the Watermist system ultra effective on fires. Conventional water-based suppression systems work on the principle of cooling the combustible surface with large droplets of water and hence totally drenching assets.

However, research has shown that the droplet size plays a vital role in killing the fire while protecting assets from collateral damage. When these fine droplets of water enter the fire zone, there is a rapid exchange of heat which cools the fire and converts the droplets into steam.

The smaller the size of the droplet, the larger is the surface area that it can cover for heat absorption and evaporation, thus resulting in lesser consumption of water to suppress the fire.



WATERMIST GENERATION TECHNOLOGY

Watermist can only be generated when water is passed through the nozzles at a very high pressure.

Ceasefire uses three technologies by which water can be converted to be a more potent fire extinguishing agent:

1. Pump-Based System

A large area where higher quantities of Watermist may be required to curb a fire needs a bigger source of water. In such cases, the water is stored in a local tank/reservoir which is connected to a pump and in the event of a fire, the high-powered pump propels water from the reservoir/tank efficiently to the pipes and specially designed nozzles.



2. Rotor-Based System

In cases where suppression systems protect smaller areas, a self-contained pulse mist-based system is used. Water is stored in nitrogen pressurised cylinders connected with detectors, pipes and nozzles. In an event of fire, the pressurised water is pushed through the specialised rotor and a little propellant (Nitrogen) is also released into the water pipe via an air tube to create a bubbled mixture of water and nitrogen which arrives at the nozzle.

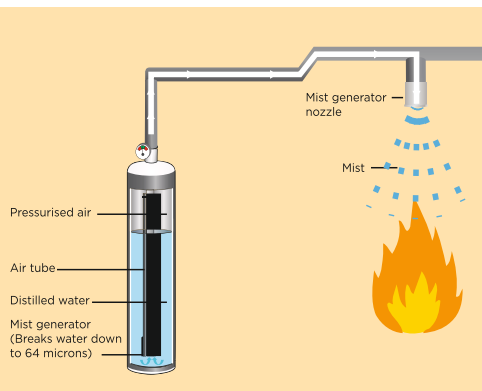

3. Large Quantity of Stored Compressed Air

In this system, compressed air is stored separately to be mixed with water only at the time of activation. When the system gets activated, water and compressed air mix together from two different sources to spray Watermist through the specialized nozzle.



DETECTION SENSORS

The detection module of Ceasefire's watermist-based adjustable alarm system can be utilised with a wide range of alarm systems and can be tailored according to specific needs and requirements. It monitors and

detects the fire condition of the protected area, making the system more intelligent (not included in the standard package and to be sourced locally).

■ Conventional Heat Detector

■ Rate of Rise Detector

■ Aspiration Detection System

■ Linear Heat Sensing Cable

■ Fixed Temperature Detector

■ Conventional Smoke Detector

■ Flame Detector

■ Conventional Heat Detector



NOZZLES

OVERVIEW:

The minimal water usage, combined with Ceasefire nozzles generate super fine Watermist droplets, means the mist quickly vaporizes in the fire zone, surrounds the atmosphere and causes no harm to delicate equipments. By adjusting the nozzle variant, water volume and air pressure parameters, we can control the qualities of the mists it generates. Droplets can range in size from 10 microns to 150 microns while mist streams may be limited to several centimetres or extended up to 12 metres. This unique flexibility allows Ceasefire to create optimal mist solutions for a broad range of applications.

All the products at Ceasefire are extensively tested in the world's largest, purpose-built, state-of-art fire test laboratories to guarantee that even the largest scale designs are fully proven in real fire conditions.

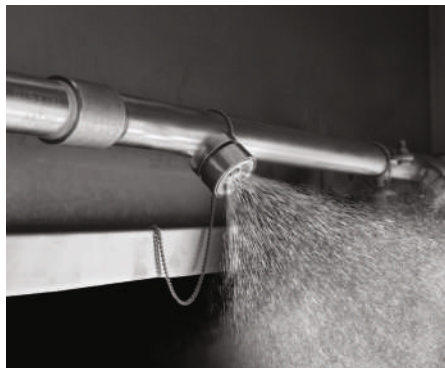

LPS 1666
Cert/LPCB Ref. 1329J

Our all-new range of Watermist Nozzles is broadly classified into:

Single Fluid-Based System

Here water and air have a single inlet and outlet. Under this application we have two types of nozzles –

Open Nozzles are those that are pressurised with water till the deluge or solenoid valve.

Closed Nozzles are those that are pressurised with the water up till the nozzle.



Twin Fluid Technology

Here there are two separate inlets and outlets for water and air to form Watermist. Only open nozzles can be utilised in this application.



GENERATOR AUTO-QUELL SYSTEM

OVERVIEW:

Generators produce a lot of heat. They're also powered by fuel, and placed in areas that are difficult to access quickly. By the time a fire is detected and put out, it could be too late.

The Ceasefire Watermist Suppression System is fully equipped to detect and suppress such fires automatically, without any collateral damage. Being Watermist-based, it tackles fires efficiently, and helps reduce the time and money taken to clean up and re-establish damaged property. With non-damaging, non-corrosive technology, it also ensures zero downtime.



FEATURES:

- Works on Class A, B, C and Electrically charged devices.
- Does not require any power supply.
- Smart detection mechanism eliminates the need for human intervention.
- Offers 24x7 protection.
- Flexible tubing accesses difficult areas easily.
- Environment-friendly.
- No collateral damage.
- Economical replacement for traditional sprinkler systems.
- Specially designed nozzles dispense microscopic droplets of water below 70 microns.

The Complete System:

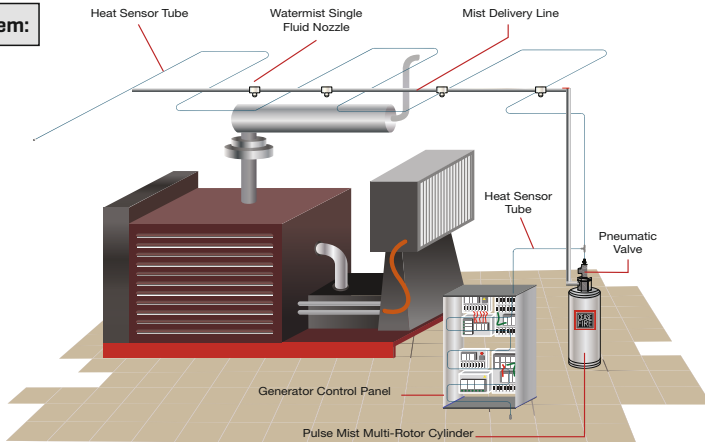

Scan code for Tech specs, Application areas and Product video.



TRANSFORMER AUTO-QUELL SYSTEM

OVERVIEW:

Transformers are vital for any operation to run smoothly. But the oil that fuels them, coupled with high temperatures generated and the presence of electricity, makes the area vulnerable to fires. With transformers often being placed in remote areas or areas that aren't easily accessible, there's always the chance that a fire will not be extinguished in time.

The Ceasefire Watermist-based Suppression System is perfect for such environments as it self-activates, detects and suppresses the fire right when it ignites. Watermist confines the fire in or around the transformer area and extinguishes it before it spreads, thus ensuring zero collateral damage.

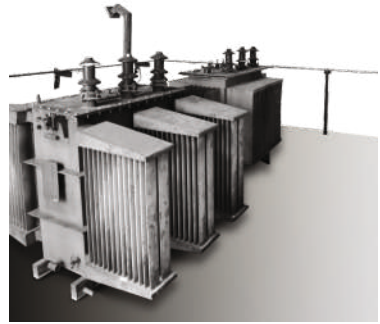

Tested by IBS



FEATURES:

- Works on Class A, B, C and Electrically charged devices.
- Does not require any power supply.
- Smart detection mechanism eliminates the need for human intervention.
- Offers 24x7 protection.
- Flexible tubing accesses difficult areas easily.
- Environment-friendly.
- No collateral damage.
- Economical replacement for traditional sprinkler systems.

The Complete System:

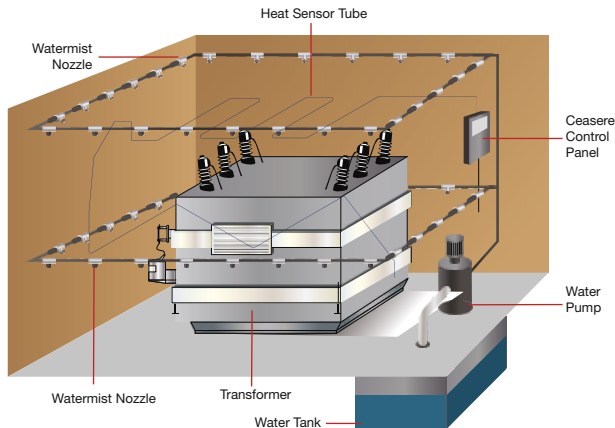

Scan the QR code for additional information about the product.

SWIFT

OVERVIEW:

Ceasefire's SWIFT (Self Activated Watermist Instant Flooding Technology) is an automatic watermist based total flooding system that is designed to not only extinguish flames effectively but also reduce the risk of collateral damage to a very large extent.

The agent being fine mist evaporates rapidly when dispersed on fire, bringing down temperature to below combustion levels and extinguish flames quickly.

The system is designed to protect large spaces and are ideally suited for spaces with sensitive equipment and expensive machinery.

FEATURES:

- Works on Class A, B, C, and fires involving Electrically charged devices.
- No damage to human life or property.
- Covers a larger surface.
- Cost effective, eco-friendly alternative to chemical systems.



The Complete System:

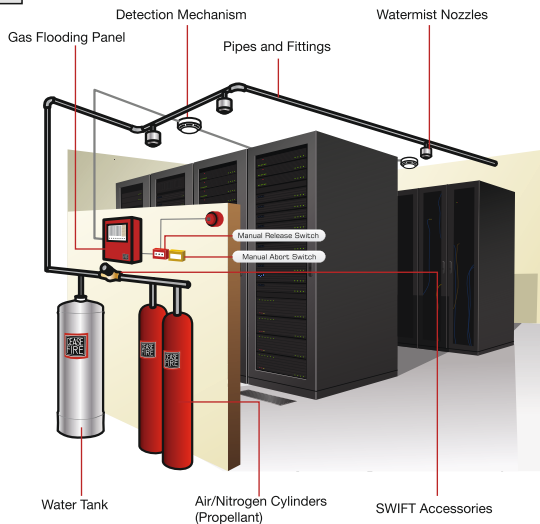

Scan code for Tech specs, Application areas and Product video.



INDOOR AUTO-QUELL SYSTEM

OVERVIEW:

The Ceasefire Watermist Auto-Quell System is a revolutionary, all-purpose detection and fire suppressant system solution. A network of detection devices, special watermist nozzles and a connection to a water tank is installed indoors. In the event of a fire, the system kicks into action in seconds.

The specially designed nozzles dispense watermist, onto the fire affected area, quickly putting out the flames as well as bringing the temperature down to non-combustion levels.



FEATURES:

- Works on Class A, B, C and Electrically started fires, and is suitable for a variety of applications.
- Smart detection mechanism eliminates the need for human intervention.
- Offers 24x7 protection.
- Flexible tubing accesses difficult areas easily.
- Environment-friendly.
- No collateral damage.
- Reduced water consumption.
- Economical replacement for traditional sprinkler systems.

The Complete System:

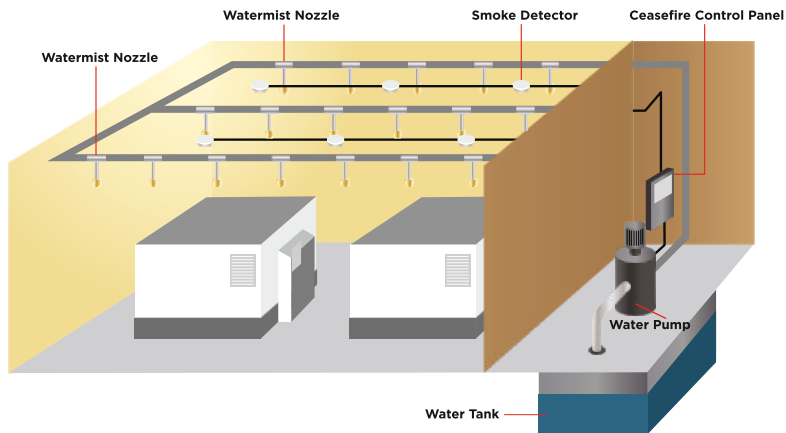

Scan the QR code for additional information about the product.

WINNING TRUST WORLDWIDE

Decades of safeguarding lives and protecting assets worldwide with over **3 million Fire Extinguishers** and over **25000 Specialised Fire Suppression Systems** protecting wide range of spaces like Rooms, Kitchens,

Electrical Panels, Server Racks, Mobile Towers, Machinery and more for our clients ranging from Start Ups to Unicorns and some of the biggest **global corporate giants**.



HONDA



HSBC



HYUNDAI



MITSUBISHI



Nestlé



ORIFLAME
SWEDEN



Unilever



unicef



and Many More...

Ceasefire Industries Private Limited

B1/H1, 2nd Floor, Mohan Cooperative Industrial Estate, Mathura Road,
New Delhi - 110044

Tel: 011-4184 6800 | Call our Free Hotline : 1800 120 3473 / +91 9540 666 666

Website : www.ceasefire.in



Scan the QR code
to visit our website

Follow us on:



Regular R&D and product improvisations may lead to change in product specifications in this catalogue, without any prior notice.